

DigiTRAK[®] **F5**[®]

Directional Drilling Locating System

Operator's Manual

403-2500-00-E, Oct 2013

© 2010–2013 by Digital Control Incorporated. All rights reserved.

Trademarks

The DCI logo, CableLink[®], DataLog[®], DigiTrak[®], Eclipse[®], F2[®], F5[®], iGPS[®], MFD[®], SST[®], target-in-the-box[®], Target Steering[®], and TensiTrak[®] are U.S. registered trademarks and DucTrak[™], FBC[™], FBP[™], F Series[™], FSD[™], FasTrak[™], LWD[™], SBP[™], SE[™], SED[™], SuperCell[™], and TeleLock[™] are trademarks of Digital Control Incorporated.

Limited Warranty

All products manufactured and sold by Digital Control Incorporated (DCI) are subject to the terms of a Limited Warranty. A copy of the Limited Warranty is included at the end of this manual; it can also be obtained by contacting DCI Customer Service, 425-251-0559 or 800-288-3610, or at DCI's website, www.digitrak.com.

Important Notice

All statements, technical information, and recommendations related to the products of DCI are based on information believed to be reliable, but the accuracy or completeness thereof is not warranted. Before using any DCI product, the user should determine the suitability of the product for its intended use. All statements herein refer to DCI products as delivered by DCI and do not apply to any user customizations not authorized by DCI nor to any third-party products. Nothing herein shall constitute any warranty by DCI nor will anything herein be deemed to modify the terms of DCI's existing Limited Warranty applicable to all DCI products. The most recent version of this manual is available on DCI's [website](http://www.digitrak.com).

FCC Compliance Statement

This equipment complies with Part 15 of the Rules of the FCC and with Industry Canada license-exempt RSS standards and with Australia Class License 2000 for LIPD (low interference potential devices). Operation is subject to the following two conditions: (1) this equipment may not cause harmful interference, and (2) this equipment must accept any interference received, including interference that may cause undesired operation. DCI is responsible for FCC compliance in the United States: Digital Control Incorporated, 19625 62nd Ave S, Suite B103, Kent WA 98032; phone 425-251-0559 or 800-288-3610.

Changes or modifications to any DCI equipment not expressly approved and carried out by DCI will void the user's Limited Warranty and the FCC's authorization to operate the equipment.

CE Requirements



DigiTrak receivers are classified as Class 2 radio equipment per the R&TTE Directive and may not be legal to operate or require a user license to operate in some countries. The list of restrictions and the required declarations of conformity are available on DCI's website, www.digitrak.com, under the Service & Support tab. Click on DOWNLOADS and select from the CE Documents pull-down menu to download, view, or print the documents.

Contact Us

<p>United States <i>DCI Headquarters</i></p>	<p>19625 62nd Ave S, Suite B103 Kent, Washington 98032, USA +1.425.251.0559 / 1.800.288.3610 +1.425.251.0702 fax dcidigital-control.com</p>
<p>Australia</p>	<p>2/9 Frinton Street Southport QLD 4215 +61.7.5531.4283 +61.7.5531.2617 fax dciaustralia-digital-control.com</p>
<p>China</p>	<p>368 Xingle Road Huacao Town Minhang District Shanghai 201107, P.R.C. +86.21.6432.5186 +86.21.6432.5187 fax dcichina-digital-control.com</p>
<p>Europe</p>	<p>Brueckenstraße 2 97828 Marktheidenfeld Germany +49.9391.810.6100 +49.9391.810.6109 fax dcieurope-digital-control.com</p>
<p>India</p>	<p>DTJ 1023, 10th Floor DLF Tower A, DA District Center Jasola, New Delhi 110044 +91.11.4507.0444 +91.11.4507.0440 fax dcindia-digital-control.com</p>
<p>Russia</p>	<p>Molodogvardeyskaya Street, 4 Building 1, Office 5 Moscow, Russia 121467 +7.499.281.8177 +7.499.281.8166 fax dcirusssia-digital-control.com</p>

Dear Customer,

Thank you for choosing a DigiTrak locating system. We are extremely proud of the equipment we have been designing and building in Washington State since 1990. We believe in providing a unique, high-quality product and standing behind it with superior customer service and training.

Please take the time to read this entire manual, especially the section on safety. Also, please fill in the product registration card provided with this equipment and either mail it to DCI headquarters, fax it to us at 253-395-2800, or complete and submit the form online at our website, www.digitrak.com. We will put you on the Digital Control mailing list and send you product upgrade information and our *FasTrak* newsletter.

Feel free to contact us if you have any problems or questions. Our Customer Service department is available 24 hours a day, 7 days a week. International contact information is available on our website.

As the horizontal directional drilling industry grows, we're keeping our eye on the future to develop equipment that will make your job faster and easier. Visit us online any time to see what we're up to.

We welcome your questions, comments, and ideas.

Digital Control Incorporated
Kent, Washington
2013

See our DigiTrak Training Videos on YouTube at www.youtube.com/dcikent.

Table of Contents

Safety Precautions and Warnings	1
General	1
Equipment and Battery Disposal	2
Pre-Drilling Testing	2
Interference	2
Equipment Maintenance.....	3
Introduction	4
Receiver	5
General Description.....	5
Toggle and Trigger Switches	6
Audible Tones.....	6
Power On	6
F5 Receiver Menus	8
Main Menu	8
Locate Mode	9
Power Off.....	9
Calibration Menu	9
Height-Above-Ground (HAG) Menu	9
Settings Menu.....	10
Transmitter Selection Menu	12
Drill DataLog Menu	13
Diagnostics Menu	13
System Info Menu	16
Pressure-Tension DataLog Menu	16
Locating Screens.....	17
Locate Mode Screen	17
Depth Mode Screen	19
Predicted Depth Screen.....	19
Depth Display Screen, No Data	20
Standard Receiver Screen Symbols	20
Using the Keypad	22
Transmitters	23
Types of Transmitters	23
Batteries and Power On/Off.....	25
Installing Batteries / Power On.....	25
Transmitter Battery Status	26
Sleep Mode (Automatic Shutdown) / Power Off	27
Transmitter Housing Requirements	27
Transmitter Selection.....	28
Transmitter Selection Menu Options	29

Changing the Frequency of a “19/12” Dual-Frequency Transmitter.....	31
Above Ground (Pre-Bore Pitch Method)	31
Below Ground (Mid-Bore Roll Method).....	31
Temperature Status and Overheat Indicator.....	32
Transmitter Temperature Warning Tones	32
Transmitter Overheat Indicator (Temp Dot).....	33
Remote Display	34
General Description.....	34
Power Options.....	34
Installing the Battery Pack or Brace Insert.....	34
Connecting the DC Power Cable	35
Powering On and Off.....	35
Keypad	36
Viewing Angle and Visor.....	36
Main Menu	37
Remote Mode.....	37
Settings	38
Adjust Contrast.....	38
Display Screens	39
Remote Mode Locating Screen	39
Depth Screen.....	40
Predicted Depth Screen.....	41
Battery Charger	42
General Description.....	42
Checking Battery Status.....	42
Installing and Removing the Battery Pack.....	43
AC/DC Power Setup.....	43
Charging a Battery Pack	43
Battery Charger Status Indicators	44
Warnings and Precautions	45
Getting Started	46
Power on Receiver, Remote Display, and Transmitter	46
Receiver.....	46
Remote Display.....	46
Transmitter	47
Conduct Interference Check.....	47
What Interference Is and How to Check for It	47
Interference Noise Check	48
Roll/Pitch Check	49
Suggestions for Dealing with Interference	50
Calibrate Receiver to Transmitter	50
1-Point Calibration (Above Ground)	52
2-Point Calibration (In Ground).....	53
View Calibration	55
Set Roll Offset	56
Enable Roll Offset.....	56
Disable Roll Offset.....	57
Set Height-Above-Ground (HAG) Distance	57

Locating	59
Locating Basics	60
Locate Points (FLP & RLP) and Locate Line (LL)	60
Effects of Depth, Pitch, and Topography on Distance Between FLP and RLP	61
Marking Locate Points	62
Standard Method for Locating the Transmitter	63
Finding the Front Locate Point (FLP)	63
Finding the Locate Line	65
Finding the RLP to Confirm Transmitter Heading and Position	67
Tracking “On-the-Fly”	69
Off-Track Locating	70
Target Steering	73
Feasible Target Depth and Positioning the Receiver as a Target	73
Setting the Receiver for Target Steering	74
Steering to the Target	75
Target Steering in Interference Areas	76
Turn Off Target Steering	76
Appendix A: System Specifications and Maintenance Requirements	77
Power Requirements	77
Environmental Requirements	77
General Transmitter Care Instructions	78
Battery Pack Storage	78
Appendix B: Projected Depth Versus Actual Depth and the Fore/Aft Offset	79
What Happens When the Transmitter Is Steep and Deep	79
Appendix C: Calculating Depth Based on Distance Between FLP and RLP	84
Appendix D: Reference Tables	85
Depth Increase in Inches (Centimeters) per 10-foot (3-meter) Rod	85
Depth Increase in Inches (Centimeters) per 15-foot (4.6-meter) Rod	86

LIMITED WARRANTY

Safety Precautions and Warnings

Carefully review this manual and be sure you always operate your DigiTrak locating system properly to obtain accurate depth, pitch, roll, and locate points. If you have any questions about the operation of the system, please contact DCI Customer Service for assistance.

General



Warning All operators must read and understand the following safety precautions and warnings and must review this operator's manual before using a DigiTrak Locating System.



Serious injury and death can result if underground drilling equipment makes contact with an underground utility such as a high-voltage electrical cable or a natural gas line.



Substantial property damage and liability can result if underground drilling equipment makes contact with an underground utility such as a telephone, cable TV, fiber-optic, water, or sewer line.



Work slowdowns and cost overruns can occur if drilling operators do not use the drilling or locating equipment correctly to obtain proper performance.



DCI equipment is not explosion-proof and should never be used near flammable or explosive substances.



In the event of electrostatic shock, the display screen may go blank. No data loss will occur. Click the trigger to reset the receiver, or toggle down to reset the remote display.



Hot surfaces can occur on cable transmitters if housing requirements are not met. Always ensure the transmitter is installed properly in the housing during use.

Directional drilling operators **MUST** at all times:

- Understand the safe and proper operation of drilling and locating equipment, including the use of ground mats and proper grounding procedures.
- Ensure that all underground utilities have been located, exposed, and accurately marked prior to drilling.
- Wear protective safety clothing such as dielectric boots, gloves, hard hats, high-visibility vests, and safety glasses.
- Locate and track the transmitter in the drill head accurately and correctly during drilling.
- Maintain a minimum distance of 8 in. (20 cm) from the front of the receiver to the user's torso to ensure compliance with FCC requirements.
- Comply with federal, state, and local governmental regulations (such as OSHA).
- Follow all other safety procedures.

DigiTrak locating systems cannot be used to locate utilities.

Continued exposure of the transmitter to heat due to frictional heating of the drill head can cause inaccurate information to be displayed and may permanently damage the transmitter.

Remove the batteries from all system components during shipping and prolonged storage; damage caused by leakage may occur.

Equipment and Battery Disposal



This symbol on equipment indicates that the equipment must not be disposed of with your other household waste. Instead, it is your responsibility to dispose of such equipment at a designated collection point for the recycling of batteries or electrical and electronic equipment. If the equipment contains a banned substance, the label will show the pollutant (Cd = Cadmium; Hg = Mercury; Pb = Lead) near this symbol. Before recycling, ensure batteries are discharged or the terminals are covered with adhesive tape to prevent shorting. The separate collection and recycling of your waste equipment at the time of disposal will help conserve natural resources and ensure it is recycled in a manner that protects human health and the environment. For more information about where you can drop off your waste equipment for recycling, please contact your local city office, your household waste disposal service, or the shop where you purchased the equipment.

The battery charger provided with your DigiTrak locating system is designed with adequate safeguards to protect you from shock and other hazards when used as specified within this document. If you use the battery charger in a manner not specified by this document, the protection provided may be impaired. Do not attempt to disassemble the battery charger, it contains no user-serviceable parts. The battery charger shall not be installed into caravans, recreational vehicles, or similar vehicles.

Pre-Drilling Testing

Before each drilling run, test your DigiTrak locating system with the transmitter inside the drill head to confirm it is operating properly and providing accurate drill head location and heading information.

During drilling, the depth will not be accurate unless:

- The receiver has been properly calibrated and the calibration has been checked for accuracy so the receiver shows the correct depth.
- The transmitter has been located correctly and accurately and the receiver is directly above the transmitter in the drill head underground or at the front locate point.
- The receiver is placed on the ground or held at the correct height-above-ground distance, which has been set correctly.

Always test calibration after you have stopped drilling for any length of time.

Interference

Interference can cause inaccuracies in the measurement of depth and loss of the transmitter's pitch, roll, or heading. Always perform a background noise check prior to drilling.

- Sources of interference include, but are not limited to, traffic signal loops, invisible dog fences, cable TV, power lines, fiber-trace lines, metal structures, cathodic protection, telephone lines, cell phones, transmission towers, conductive earth, salt, salt water, rebar, and radio frequencies.
- Interference at the remote display may also occur from other sources operating nearby on the same frequency, such as car rental agencies using their remote check-in modules or other directional drilling locating equipment.

- Background noise must be minimal and signal strength must be at least 150 points above the background noise during all locating operations.
- Because this equipment may generate, use, and radiate radio frequency energy, there is no guarantee that interference will not occur at a particular location. If this equipment does interfere with radio or television reception, which can be determined by powering the equipment off and on, try to correct the interference using one or more of the following measures:
 - Reorient or relocate the receiving antenna.
 - Increase the separation between the receiver and affected equipment.
 - Consult the dealer, DCI, or an experienced radio/TV technician for help.
 - Connect the DCI equipment to an outlet on a different circuit

Equipment Maintenance

Turn off all equipment when not in use.

Store the equipment in cases, away from heat, cold, and moisture. Test to confirm proper operation prior to use.

Clean the screens on the receiver and remote display using a damp soft cloth without chemicals or cleaning agents.

Clean the receiver, remote, and battery charger case using only a soft moist cloth and mild detergent.

Do not use chemicals to clean the transmitter.

Inspect the equipment daily and contact DCI if you see any damage or problems. Do not disassemble or attempt to repair the equipment.

Do not store or ship this equipment with batteries inside. Always remove the batteries from the equipment before shipping or periods of non-use.

Introduction



DigiTrak F5 Locating System

The DigiTrak F5 Locating System is used during horizontal directional drilling operations to locate and track a transmitter installed in the drill head. A complete F5 system consists of a handheld receiver, a transmitter, a remote display on the drill rig, a battery charger, and three rechargeable lithium-ion (Li-ion) battery packs for powering the receiver and remote display.

There are several transmitter options available for use with the F5 system. These include five frequency options (1.3 kHz, 8.4 kHz, 12 kHz, 18.5 kHz, and 19.2 kHz), dual-frequency transmitters, and a cable transmitter. The options also include fluid pressure transmitters (FPTs) that monitor the pilot hole annular mud pressure, the TensiTrak transmitter that monitors the pullback force between the reamer and the product being pulled, and the Steering Tool (SST) transmitter for drilling where walkover tracking is not possible.

The F5 system includes a DataLog function that records data points along the bore path. The drill data can then be uploaded to a computer with DigiTrak LWD (Log-While-Drilling) software, which allows you to format, analyze, view, and print DataLog files. See the [DigiTrak LWD DataLog System Operator's Manual](#) for complete information.

Receiver

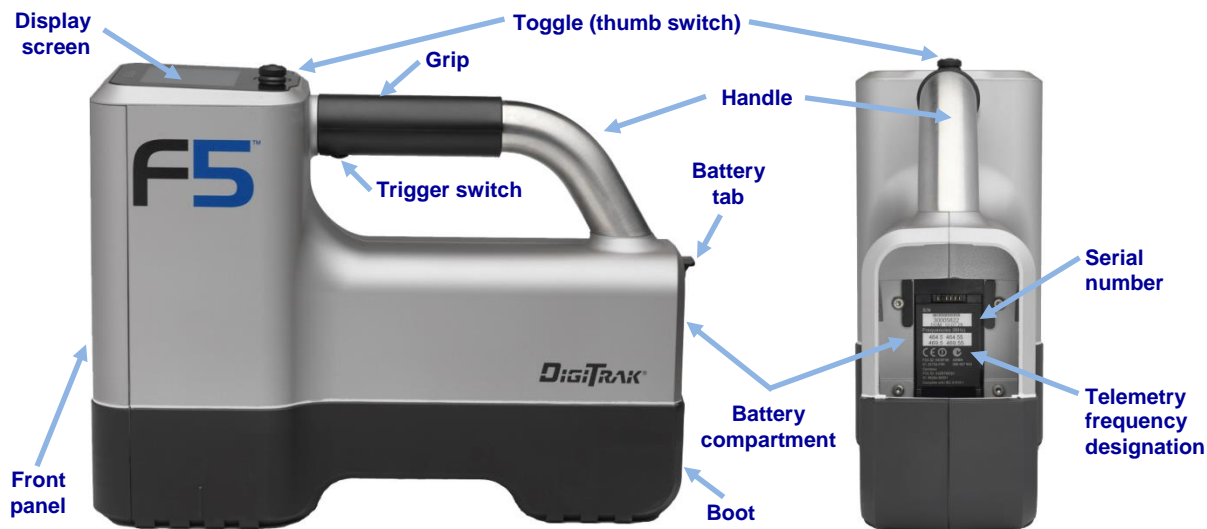

F5 Receiver – Side and Back Views

General Description

The F5 receiver is a handheld unit used for locating, tracking, and mapping the path of an F5 or F Series transmitter. The receiver converts signals from the transmitter and displays depth, pitch, roll, temperature, battery level, and (optionally) fluid pressure. The F5 receiver sends this same information to the remote display on the drill rig.

To meet regional requirements and for proper communication, the telemetry frequency designation for the receiver must match that for the remote display. The telemetry frequency designation is identified on the F5 receiver's serial number label located inside the battery compartment. It must match one of those listed on the remote display's serial number label located on the back of the unit (see [Remote Display](#) on page 34).

The receiver and transmitter must also meet specific operational requirements for different global regions. A regional designation number is provided in the receiver's software (see figure titled [Receiver Startup Screen](#) on page 7). This number must match the one stamped on the transmitter for proper communication.

Prior to use, the receiver must be set to detect the transmitter being used and be calibrated for use with that transmitter (see [Calibrate Receiver to Transmitter](#) on page 50).

Toggle and Trigger Switches

The F5 receiver has two switches for operating the system: a toggle (thumb switch) located on the top of the unit and a trigger located under the handle.

- | | |
|-----------------------|---|
| Toggle Switch | Used to access and navigate menus. Moves in four directions: left, right, up (toward the display), and down (toward the handle). |
| Trigger Switch | Used to turn on the receiver, select menu options reached with the toggle switch, and change the screen view for depth readings. Click once or hold briefly, depending on the desired action. |

Audible Tones

The F5 receiver beeps to signal power on/off, confirm menu changes, and acknowledge the pass/fail status of actions, as summarized below. The receiver also beeps with transmitter temperature increases (see [Transmitter Temperature Warning Tones](#) on page 32).

- | | |
|----------------------------|--|
| Power On | A series of short beeps. |
| Power Off | Four short beeps. |
| Confirmation Signal | Four short beeps confirm menu selection has been successfully executed. |
| Failure Signal | Two long beeps indicate a problem with the menu option selected and a failure screen appears until you click the trigger or remove the battery (in the case of a critical failure). Verify your setup and try the operation again or call DCI Customer Service for assistance. |

Power On

To turn on the receiver, pull and hold the trigger briefly, then release. A series of beeps sounds, then a screen with the F5 logo displays while the receiver performs a series of self-tests, followed by the warning screen shown below.



F5 System Acknowledgement Screen

Pull and release (click) the trigger to acknowledge you have read and understand this manual. If all items of the self-tests passed, the startup screen displays.

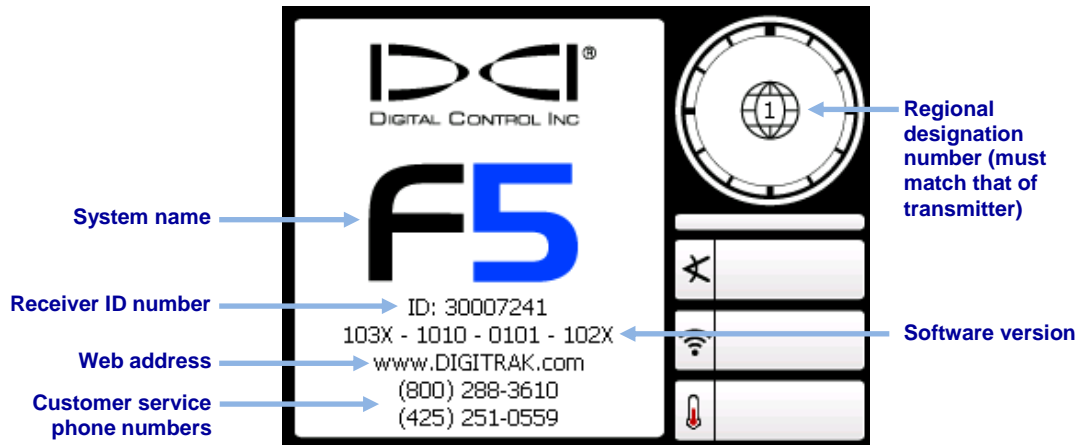

Receiver Startup Screen

Click the trigger to exit the startup screen and open the [F5 Receiver Menu](#) (see page 8).





Note If an item of the self-test fails, a warning displays and a failure message appears in place of the system name. For example, a new or reset receiver may display a message indicating a 10-ft calibration is required (see [Calibrate Receiver to Transmitter](#) on page 50). If the error is not addressed in this manual, please contact DCI Customer Service.

F5 Receiver Menus

Main Menu

To access the Main menu from the startup screen, click the trigger. When locating, you can access the Main menu by pulling the toggle switch down (toward the handle). Use the toggle to highlight different menu options and click the trigger to select a menu option.

The Main menu spans two screens, as shown below. A down arrow  in the lower right corner indicates more menu options below (on the next screen); an up arrow  indicates more options above on the previous screen.

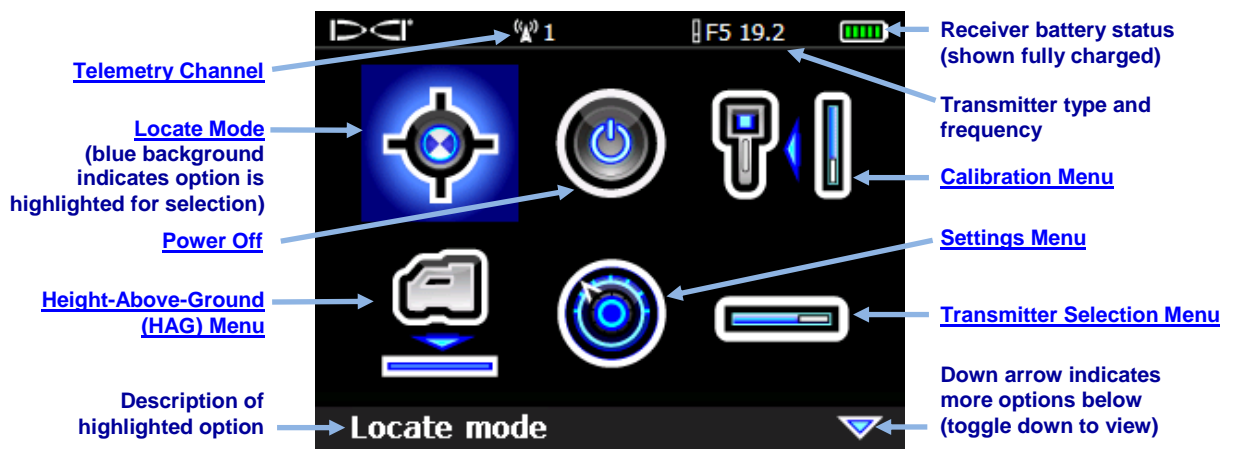

Receiver Main Menu, First Screen

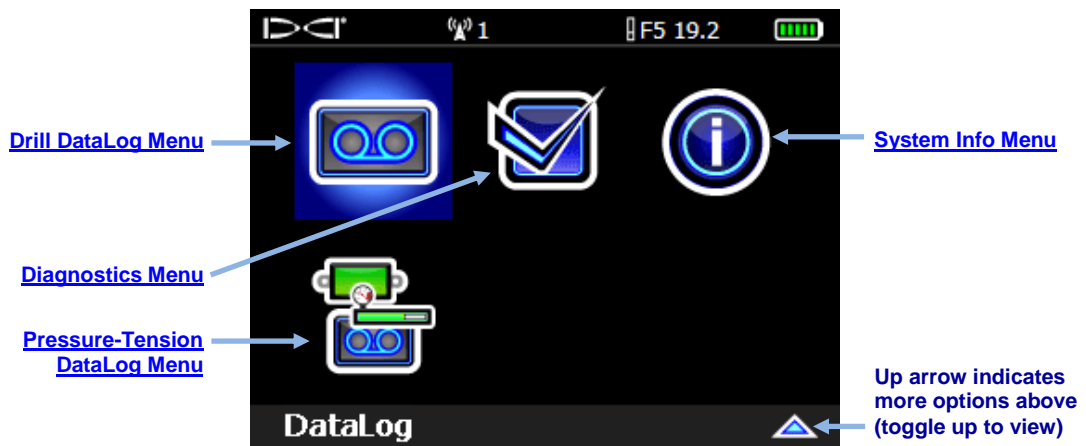

Receiver Main Menu, Second Screen

The F5 displays the receiver battery status in the top right corner, the transmitter type and frequency setting to the left of the battery status, and the current telemetry channel selection (channel 1 is shown in the preceding example) at the top of all receiver menus.

The options available on the Main menu are described in the following sections.

Locate Mode

When the receiver is detecting a signal from a transmitter, the Locate Mode  screen provides real-time data about the transmitter's location, temperature, pitch, roll, fluid pressure (when a fluid pressure transmitter is used), and signal strength. See [Locate Mode Screen](#) on page 17 for more information.

Power Off

Select Power Off  to turn the receiver off. Four short beeps will sound as the unit powers off.

Automatic Shutdown The receiver automatically shuts down after 15 minutes of inactivity or after 30 minutes when in Target Steering mode. Automatic shutdown is disabled during an [Interference Noise Check](#) (see page 15).

Calibration Menu

Use the Calibration menu  to calibrate the receiver to a transmitter with the transmitter above ground (1-point calibration) or below ground (2-point calibration). When you select this option, the calibration method previously used is highlighted for selection.

Calibration is necessary prior to first-time use and before using a different transmitter, receiver, or drill head.

See [Calibrate Receiver to Transmitter](#) on page 50 for more information.

Height-Above-Ground (HAG) Menu

Use the height-above-ground (HAG) option  to program a height measurement into the receiver so it does not need to be set on the ground for a depth reading.

See [Set Height-Above-Ground \(HAG\) Distance](#) on page 57 for more information.

The F5 always powers up with the HAG function off (disabled). HAG also automatically shuts off during calibration and must be re-enabled. Until you enable HAG, the receiver must be placed on the ground for accurate depth readings.

Settings Menu

Use the Settings menu  to set the following options:

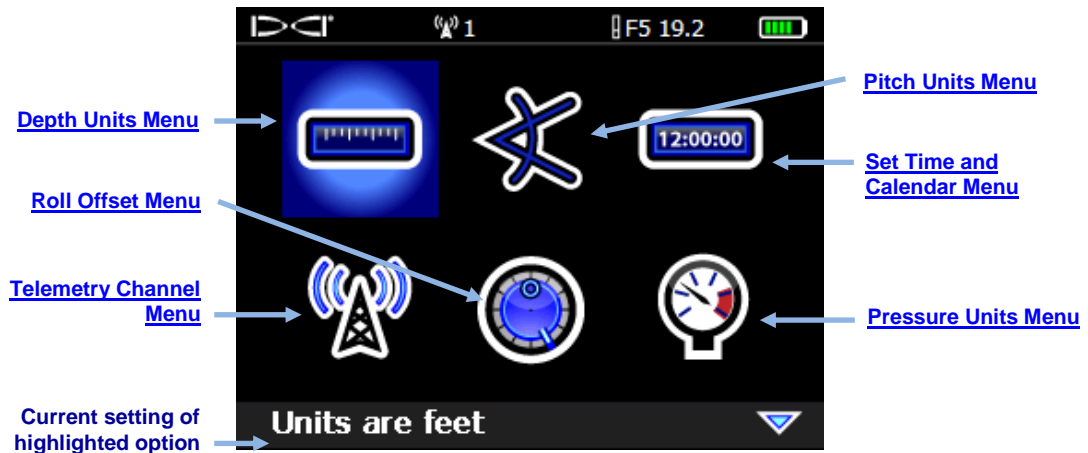

Receiver Settings Menu, First Screen

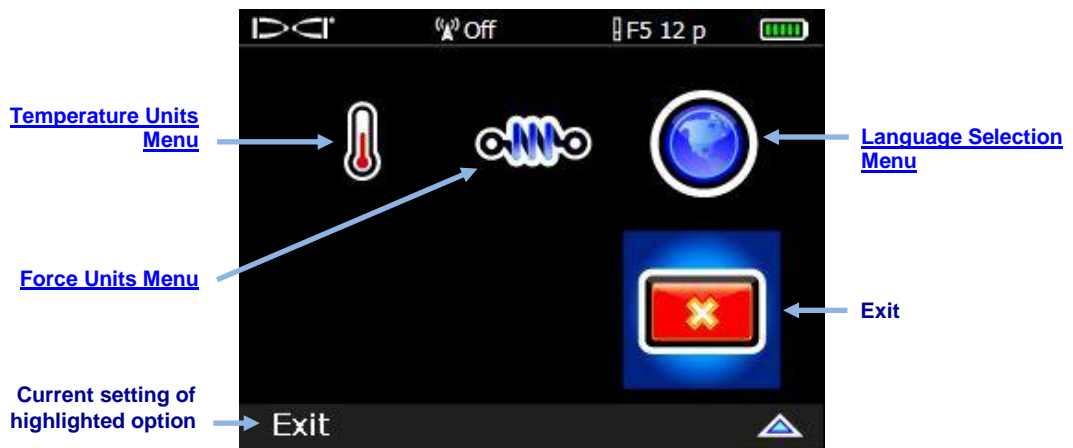

Receiver Settings Menu, Second Screen

Any changes made to settings will be saved when the receiver is turned off. DCI recommends that you program the receiver settings and the remote display settings to match each other.

Depth Units Menu

The depth units menu  has four options:

- xx" represents the use of inches only
- x'xx" represents the use of both feet and inches
- x.xx' represents the use of feet only
- x.xx m represents the use of metric units (meters and centimeters)

After a selection, the receiver beeps four times as the screen returns to the Settings menu.

Pitch Units Menu

Use the Pitch Units menu  to choose between two options: percent (x%) and degrees (x°). After a selection, the receiver beeps four times as the screen returns to the Settings menu.

Set Time and Calendar Menu

Use the Time and Calendar menu  to set the time and date on your receiver. This is necessary when you are using the DataLog function.

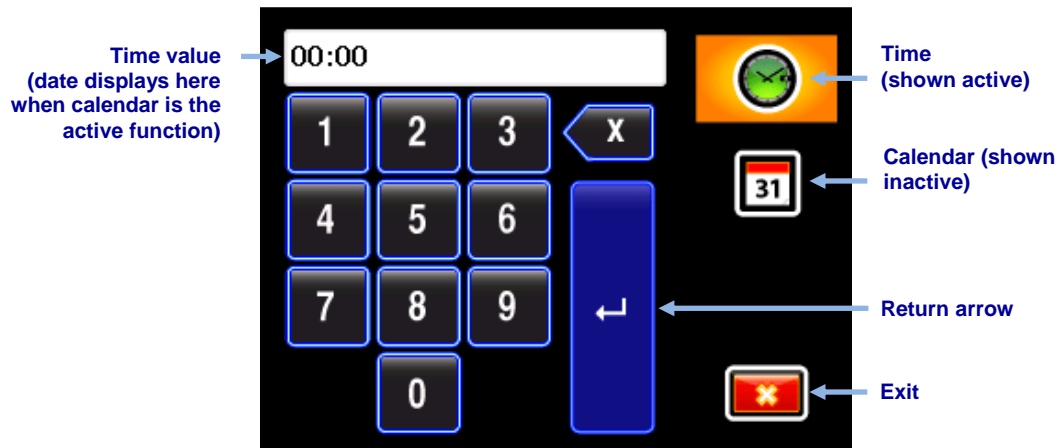

Time and Calendar Keypad

Setting the Time

The time function runs on a 24-hour clock. To set the time: 

1. Select the time icon so it is the active function.
2. Enter the time one digit at a time from left to right. For example, to set the clock to 13:39 (1:39 pm), select “1”, then 3, 3, and 9.
3. Select the blue return arrow . The receiver beeps four times as the screen returns to the Settings menu.

Setting the Calendar

The calendar function displays the date by month/day/year. To set the date: 

1. Select the calendar icon so it is the active function. The display window on the keypad changes to show a date format.
2. Enter the date one digit at a time from left to right. The date format is two digits for the month, two digits for the day, and four digits for the year (MM/DD/YYYY). For example, to set the date to January 2, 2013 (01/02/2013), select “0”, then 1, 0, 2, 2, 0, 1, and 3.
3. Select the blue return arrow . The receiver beeps four times as the screen returns to the Settings menu.

Telemetry Channel Menu

The Telemetry Channel menu  has five telemetry settings (1, 2, 3, 4, and 0). For communication to occur between the receiver and remote display, both devices must be set to the same telemetry channel. The current telemetry setting is highlighted when this menu opens.

Select the desired telemetry channel on the receiver. The receiver beeps four times as the screen returns to the Settings menu.

Select Exit to return to the Settings menu with no change to the telemetry channel setting. Select "0" to turn the telemetry function off, which conserves receiver battery life.

Roll Offset Menu

Use the Roll Offset menu  when the 12 o'clock position of the transmitter cannot be indexed to that of the drill head. Roll offset lets you program the receiver to display the roll of the drill head rather than that of the transmitter. See [Set Roll Offset](#) on page 55 for details on using this setting.

Pressure Units Menu

The Pressure Units menu  has two options: pounds per square inch (psi) and kilopascals (kPa). After a selection, the receiver beeps four times as the screen returns to the Settings menu.

Temperature Units Menu

The Temperature Units menu  has two options: Fahrenheit (F) and Celsius (C). After a selection, the receiver beeps four times as the screen returns to the Settings menu.

Force Units Menu

The Force Units menu  has two options: pounds (lb) and newtons (N). After a selection, the receiver beeps four times as the screen returns to the Settings menu. This setting is only used with the optional TensiTrak for measuring pullback pressure and tension.

Language Selection Menu

The Language Selection menu  has multiple language options. After a selection, the receiver beeps four times and restarts.

Transmitter Selection Menu

The Transmitter Selection menu  lets you select the transmitter type, model, and frequency, when applicable. See [Transmitter Selection](#) on page 28 for more information.

Drill DataLog Menu

Use the Drill DataLog menu  to record pilot hole drill data, set up new drill jobs, view and delete drill jobs from the receiver, and upload drill jobs via Bluetooth to a computer for analysis with Log-While-Drilling (LWD) software.

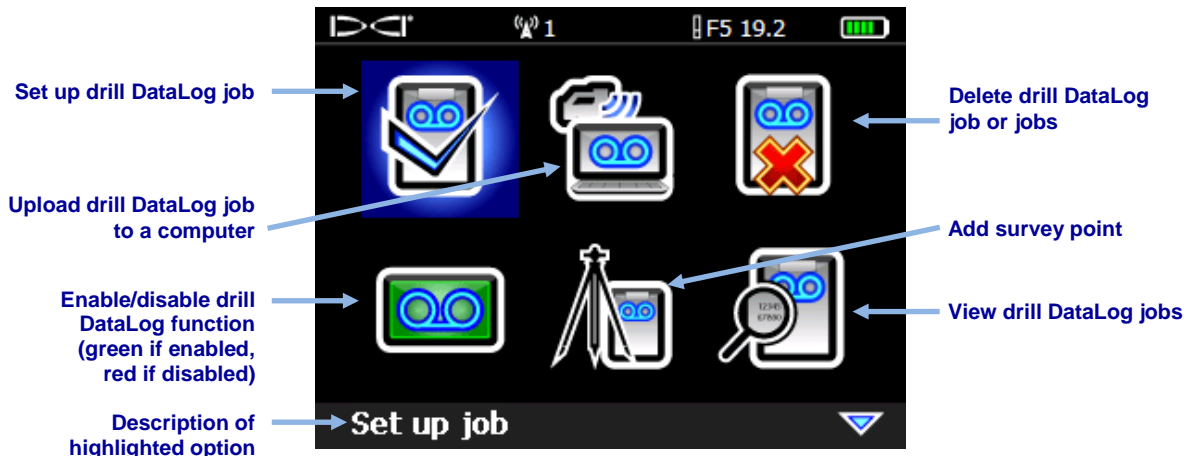

Drill DataLog Menu

The LWD software has a variety of options for analyzing, editing, and displaying DataLog drill data. Complete instructions for using the DataLog function and the supporting LWD software are provided in the separate [DigiTrak LWD DataLog System Operator's Manual](#).

Diagnostics Menu

The Diagnostics menu  lets you check the performance of your F5 receiver.

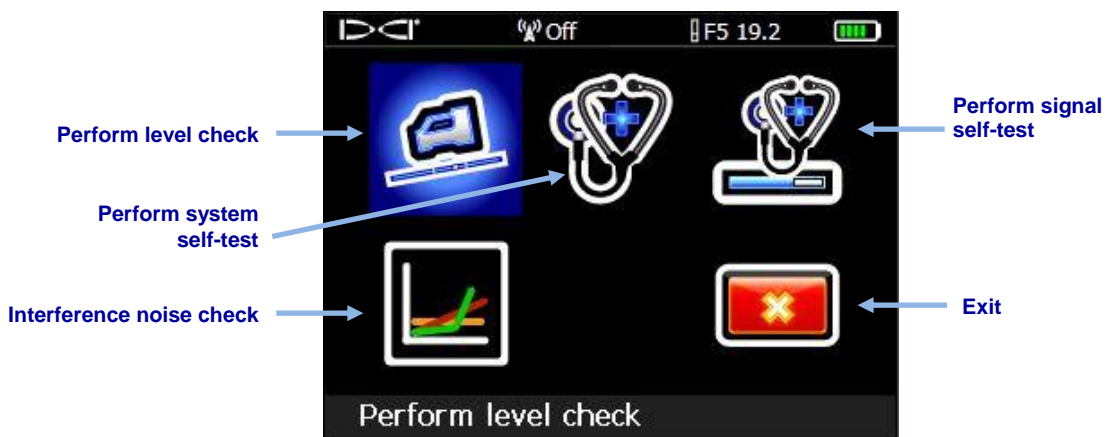

Diagnostics Menu

Perform Level Check

Perform Level Check  confirms that the internal accelerometers that measure the inclination of the receiver are working correctly. An inaccurate accelerometer would cause erroneous depth and location readings.

Place the receiver on generally level ground and click the trigger on the green icon. The ground does not have to be perfectly level. To cancel the level check and return to the Main menu at any time, click Exit.



Level Test Screen 1

Rotate the receiver 180 degrees so it faces the opposite direction, as illustrated by the icon on the screen, and click the trigger on the green icon again.

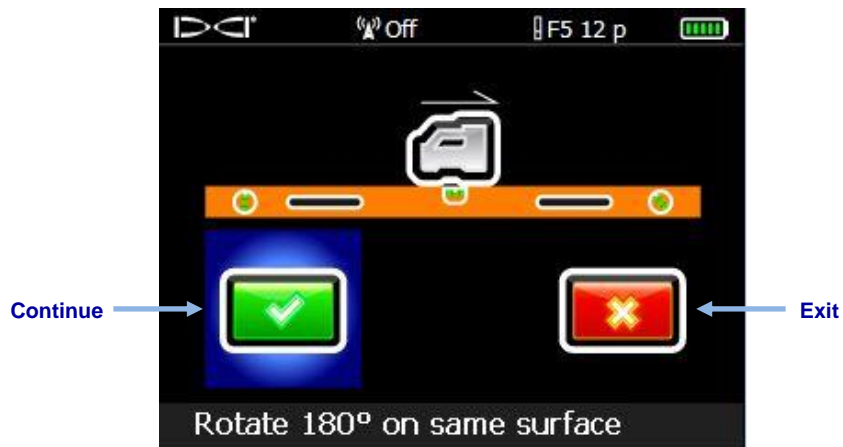

Level Test Screen 2

The receiver beeps four times, flashes a confirmation message, and returns to the Main menu.

If the level check fails, the receiver beeps twice and displays an error screen. Click Retry  and repeat the test as described above. If the check fails again, contact DCI Customer Service.

Perform System Self-Test

Perform System Self-Test  performs a system self-test on internal components. The receiver beeps four times after a successful system self-test and displays the [Receiver Startup Screen](#) shown on page 7. Click the trigger to return to the Diagnostics menu.

If the receiver returns any other results, contact DCI Customer Service.

Perform Signal Self-Test



Perform Signal Self-Test tests antenna gain calibration for all transmitter frequencies. Perform this test only in a low-noise environment with minimal interference. The transmitter signal strength as displayed in the [Locate Mode Screen](#) (see page 17) must be less than 55 counts.

At the conclusion of a successful test, the receiver beeps four times and the self-test screen displays with no errors.

Interference Noise Check



Interference Noise Check simplifies the process used to evaluate background noise and select a transmitter frequency without having to walk the bore path with pen and paper in hand. See [Interference Noise Check](#) on page 48 for a description of this feature.

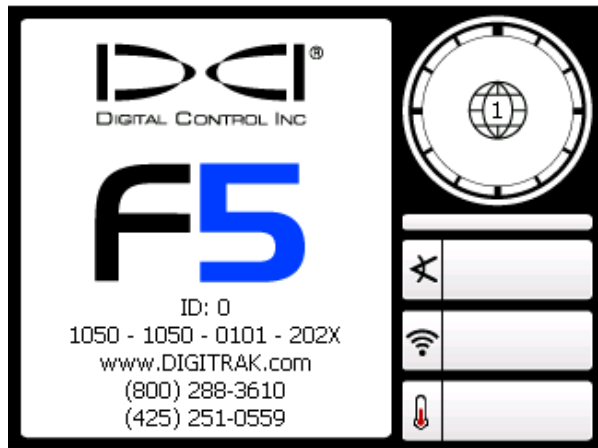

Successful Signal Self-Test Screen

Potential test failures

Background noise

If the test begins in an area with too much background noise, the test stops and the receiver displays a warning similar to **Background signal is too high**. Find a lower-noise area and try the test again.

Test Loop

If there is a problem with the depth antenna in the receiver, the receiver displays the error message **Fault: Depth Antenna Failure** on the locate mode screen and locks the receiver. Contact DCI Customer Service.

DSP channel failure

In the event of a Digital Signal Processor (DSP) channel failure, the receiver displays the error message **Critical: DSP channels** on the locate mode screen and locks the receiver. Contact DCI Customer Service.

System Info Menu

The System Info menu  displays technical system information such as ID, region, and firmware version. Use the toggle or trigger to exit to the Main menu.

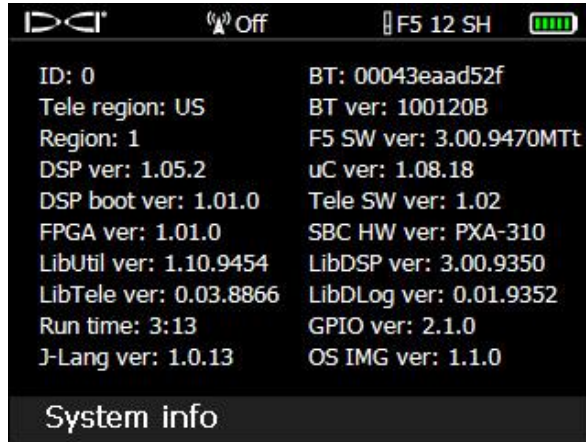

System Info Screen

Pressure-Tension DataLog Menu

Use the Pressure-Tension (P-T) DataLog menu  with fluid pressure transmitters and the TensiTrak transmitter. To enable P-T DataLog, select the red enable/disable P-T DataLog function icon shown below; the icon will change to green.

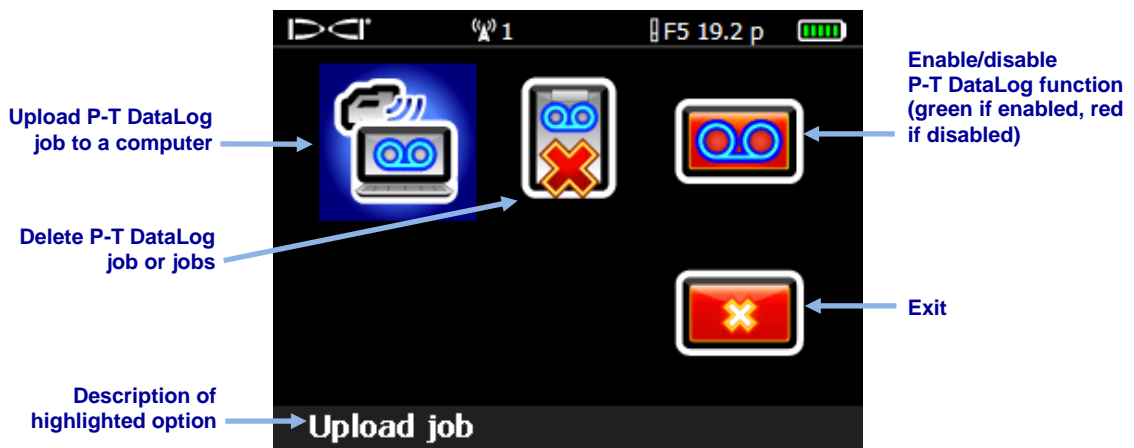

Pressure-Tension DataLog Menu

Available P-T data will always display on the Locate Mode screen, whether or not recording is enabled.

The Log-While-Drilling software for your PC has a variety of options for analyzing, editing, and displaying DataLog drill data. Complete instructions for using the Pressure-Tension DataLog function and the supporting LWD software are provided in the separate [DigiTrak LWD DataLog System Operator's Manual](#).

Locating Screens

The screens associated with locating include the Locate Mode screen, the depth mode screen, and the predicted depth screen, each of which is described briefly below. For additional information, see [Locating](#) on page 59.

Locate Mode Screen

The first option in the Main menu is Locate Mode, which displays the Locate Mode screen. When the receiver is detecting a signal from a transmitter, the Locate Mode screen provides real-time data about the transmitter's location, temperature, pitch, roll, and signal strength.

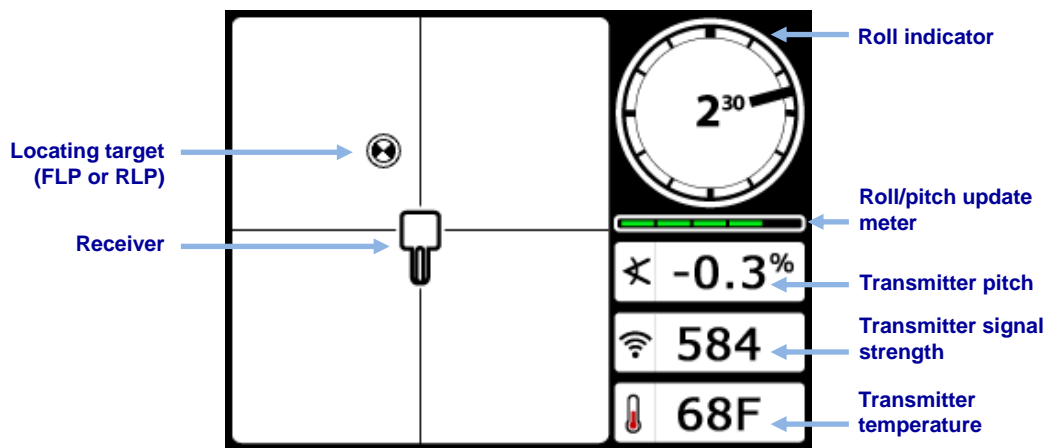

Locate Mode Screen with Transmitter in Range

The roll/pitch update meter displays the quality of roll/pitch data being received from the transmitter. When the meter is empty, no roll/pitch data is being received, and none will appear on either the receiver or the remote display. Depth and predicted depth readings may still be taken, but the receiver will assume the transmitter has a pitch of zero, as indicated by the image to the right appearing on the depth or predicted depth mode screen.



Pitch Assumed Zero

When the roll offset function (an electronic compensation to match the transmitter's 12 o'clock position to the drill head's 12 o'clock position) is enabled, the roll indicator will change to a circle and "RO" appears at the bottom left of the roll indicator. For more information on using roll offset, see [Set Roll Offset](#) on page 56.



Roll Offset Activated

When the receiver is set to detect an F5 12 kHz transmitter and a "12/1.3" dual-frequency transmitter (part number F5D 12/1.3 or F5Dp 12/1.3) is being used in dual mode, the dual transmitter symbol will appear at the upper left of the roll indicator as shown at right. The letters "DL" or "DH" will accompany this symbol when



Dual Transmitter Detected

the receiver is set to detect the dual low (1.3 kHz) or dual high (12 kHz) frequency, respectively. For proper communication, set the receiver to detect the dual mode transmitter as described in [Transmitter Selection](#) on page 28.

When using a fluid pressure (P-T) transmitter, the Locate Mode screen has an additional data field and recording symbol:

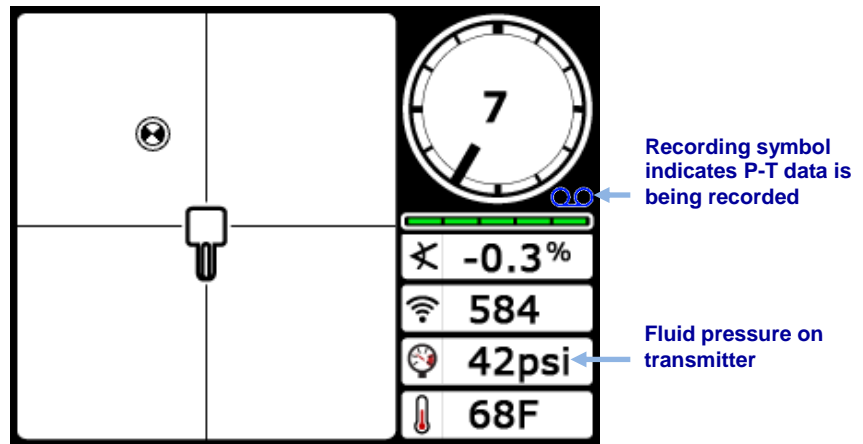

Locate Mode Screen with Fluid Pressure Data

When using a TensiTrak monitoring system during the pullback process, the Locate Mode screen displays the annular mud pressure, pullback force, and number of data points recorded. See the [DigiTrak F5 TensiTrak Pullback and Pressure Monitoring System Operator's Manual](#) for complete instructions on using the TensiTrak system.

Locate Mode Screen Shortcuts

The following shortcuts are available from the Locate Mode screen.

Task	Operation
Drill DataLog Menu (p. 13)	Hold trigger, toggle right
Depth Mode Screen (p. 19)	Hold trigger at locate line
Main Menu (p. 8)	Toggle down
Predicted Depth Screen (p. 19)	Hold trigger at forward locate point
Pressure-Tension Flag (p. 16)	Toggle right during P-T job recording
Target Steering (p. 73)	Toggle up
Transmitter Shortcut Menu (p. 29)	Hold toggle right

Depth Mode Screen

Hold the trigger with the receiver at the locate line (LL) to display the depth mode screen. There are three different depth mode screens, depending on the position of the receiver relative to the transmitter. [Locating](#) on page 59 describes how to position the receiver at the locate line.

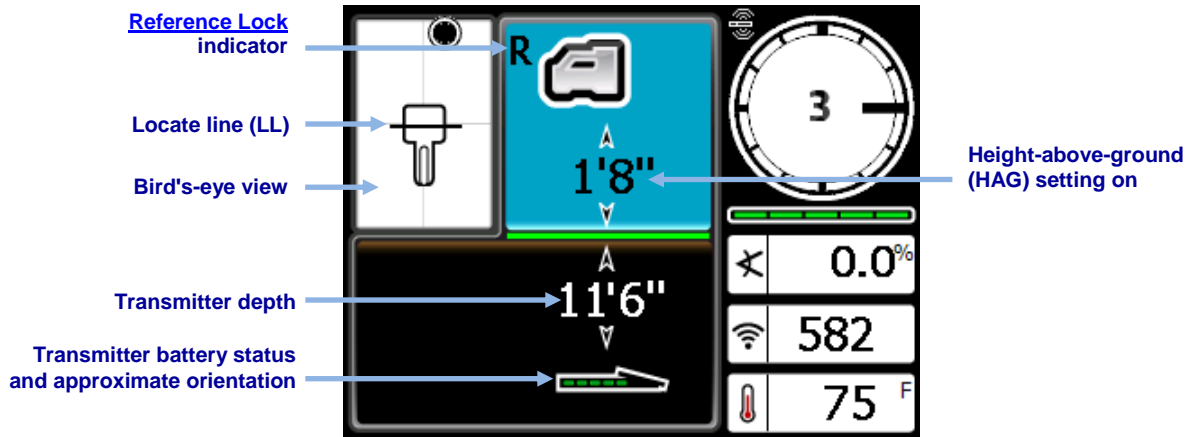

Depth Mode Screen at LL with HAG On

When the HAG setting is disabled, the receiver is shown on the ground and must be placed on the ground during depth readings.

Predicted Depth Screen

The predicted depth screen displays when the receiver is positioned at the front or rear locate point (FLP or RLP) and the trigger is held in. The predicted depth is the depth the transmitter is calculated to be at when it reaches the front locate point if it continues on its current trajectory. The predicted depth is only valid at the FLP. See [Locating](#) on page 59 for more information.

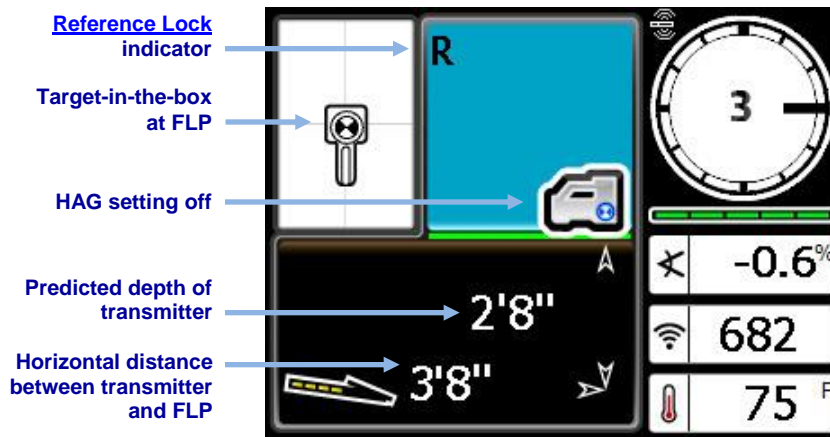

Predicted Depth Screen at FLP with HAG Off (Trigger in)

Depth Display Screen, No Data

The depth screen can be accessed at any time during locating by holding in the trigger. However, the depth screen will not display any depth or predicted depth when the receiver is not positioned at the locate line or at the front or rear locate point.

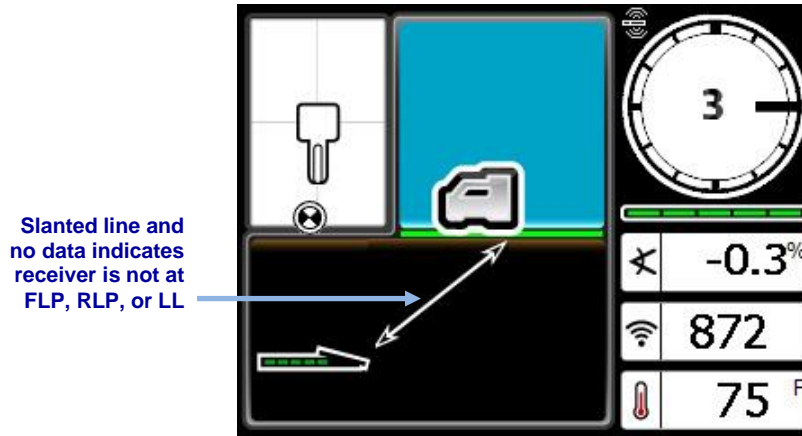

**Receiver Depth Mode Screen with HAG Disabled
(when not at FLP, RLP, or LL)**

When the HAG setting is enabled, the receiver will be shown elevated above the ground with the HAG value displayed below the receiver.

Standard Receiver Screen Symbols



Dual Transmitter – Appears to the upper left of the transmitter roll clock when the receiver is set for an F5 12 kHz or dual transmitter and a transmitter in dual mode is detected. The letters “DL” or “DH” will accompany this symbol to show whether the receiver is set to detect the dual low (1.3 kHz) or dual high (12 kHz) frequency, respectively.



Globe Icon – Identifies the regional designation number that appears on the receiver startup screen; must match the region number on the transmitter battery compartment.



Ground Level – Represents the ground for the HAG function, depth readings, and the two-point calibration procedure.



Locate Line – Represents the locate line (LL) perpendicular to the transmitter. The LL is found at some location between the front and rear locate points only after a reference point has been obtained. It is yellow at a distance, red when close, and black when the receiver approaches directly over the transmitter. During target steering, the locate line is black only. See [Locating](#) on page 59.



Locate Target – Represents the front and rear locate points (FLP and RLP). See [Locating](#) on page 59.



Locating Icon – Represents a bird’s-eye view of the receiver. The square at the top of this icon is referred to as the “box” in the terms *target-in-the-box* and *line-in-the-box* locating.

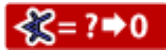

Pitch Assumed Zero – In the absence of transmitter signal, indicates the transmitter pitch is assumed to be zero during depth and predicted depth readings.



Pressure – When using a fluid pressure transmitter, the number next to this icon on the Locate Mode screen indicates the pressure reading. If the pressure reaches an over-limit condition (from 100–250 psi or 690–1760 kPa), the value will appear red. When the pressure reaches the overload condition (over 250 psi or 1760 kPa), the value will display as “+OL”.



Receiver Battery – Depicts the remaining battery life of the receiver (shown 80% full here). When empty, the icon will flash in the Locate Mode screen, signifying that it is critical to change the battery immediately.



Receiver Icon – Indicates the position of the receiver relative to the ground for the height-above-ground (HAG) function, depth readings, the two-point calibration procedure, and the Target Steering function.



Recording – Indicates that pressure-tension data is being recorded. Appears at the lower right of the transmitter roll indicator when P-T data recording is enabled.



Reference Lock – Indicates that a reference signal has been obtained for locating the transmitter. See [Locating](#) on page 59.



Roll/Pitch Update Meter – Shows the quality of data reception from the transmitter (specifically, data rate). Lets you know if you are in an area of interference or reaching the range limit of the transmitter.



Transmitter Battery/Drill Head – Depicts the remaining battery life of the transmitter when alkaline batteries are used (full battery shown here). Also used to represent the position of the drill head relative to the receiver in the depth screen.



Transmitter Pitch Angle – The number next to this icon on the Locate Mode screen indicates the transmitter pitch. It is also the menu selection icon for changing the pitch angle units between percent and degrees.



Transmitter Roll Clock – Shows the transmitter’s roll position. A line points to the roll position, and the roll value appears in the center of the clock. The number of roll positions is a function of the transmitter (12 or 24). When roll offset is used, the letters “RO” appear at the bottom left.



Transmitter Signal Strength – The number next to this icon on the Locate Mode screen indicates the transmitter signal strength.

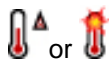

Transmitter Temperature – The number next to either of these icons shows the temperature of the transmitter. An up or down arrow will accompany a change in temperature. The icon on the right represents dangerous drilling temperatures.



Warning – Appears when there has been a failure in a self-test.

Using the Keypad

Use the keypad  for setting the height-above-ground (HAG) value, a target depth for Target Steering, date and time, and for programming rod lengths and survey points in the DataLog function.

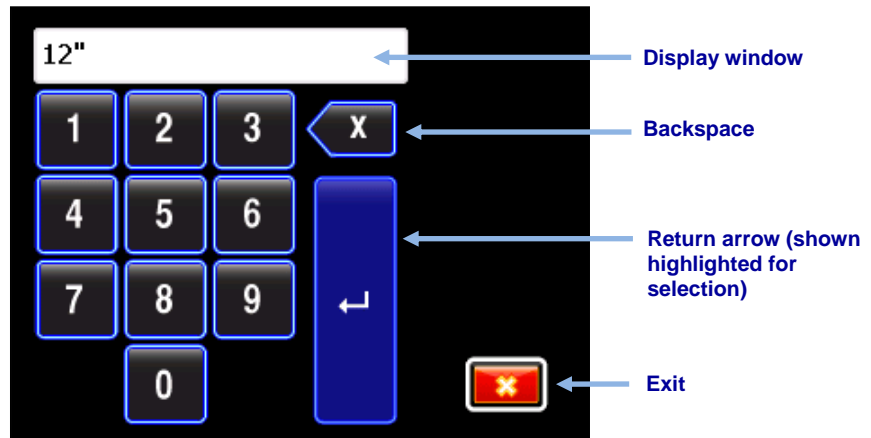

Standard Keypad

To input a value, toggle to and select the desired digits from left to right. When a decimal value is required (such as for feet only or meters), then the last two digits entered will be to the right of the decimal point. To enter a whole value, enter two zeros at the end of the value. Use backspace to delete the last digit entered. Once the desired number is in the display window, select the return arrow to lock in the value and turn on the function.

Transmitters

A transmitter fits inside the drill housing and generates a magnetic field detected by the F5 receiver. The F5 receiver must be set to match the frequency of the transmitter. The receiver must also be calibrated to the transmitter before drilling and the calibration must be verified (see [Getting Started](#) on page 46).

The transmitter and receiver must have matching regional designation numbers to communicate with each other and comply with local operating requirements. The transmitter's regional designation number is located inside the globe icon (🌐) near the serial number on long range and extended range transmitters and on the front end cap of short range transmitters.

Types of Transmitters

DCI manufactures several different F5 and F Series transmitters in five frequency options: 1.3, 8.4, 12, 18.5, and 19.2 kHz. F5 transmitters provide pitch readings in 0.1% or 0.1° increments from 0% to 100% (0° to 45°) and display roll in 24 clock positions (CP). F Series transmitters display roll in 12 clock positions.

Long range HDT transmitters measure 15 in. (38.1 cm) long and 1.25 in. (3.175 cm) in diameter, have a depth range of approximately 65 ft (19.8 m), and display roll in 24 clock positions. Several options are available, including dual frequencies and fluid pressure monitoring.



Long Range F5 Transmitter

Extended range F Series transmitters measure 19 in. (48.26 cm) long and 1.25 in. (3.175 cm) in diameter, have a depth range of approximately 85 ft (25.9 m), and display roll in 12 clock positions. They are available in 12 kHz (gray) or 19.2 kHz (black) frequencies.



Extended Range F Series Transmitters

The short-range FS transmitter measures 8 in. (20.32 cm) long and 1.00 in. (2.54 cm) in diameter, has a depth range of approximately 15 ft (4.6 m), broadcasts at 12 kHz, and displays roll in 12 clock positions.



Short Range FS Transmitter

The FC cable transmitter has a depth range of approximately 90 ft (27.4 m). It measures 19 in. (48.26 cm) long and 1.25 in. (3.175 cm) in diameter, broadcasts at 12 kHz, and displays roll in 12 clock positions. This transmitter requires a housing that will accommodate the wire and also provide a good ground connection to the base of the transmitter. For information on using the FC cable transmitter and necessary Multi-Function Cable Box (MFCB), see the [MFCB operator's manual](#) available on our website.



FC Cable Transmitter

The long range fluid pressure transmitter (FPT) provides down-hole fluid pressure readings up to 250 psi (1725 kPa) in addition to the standard transmitter data provided by other F5 transmitters. The pressure sensors are located on the front end cap, with two sensor ports situated on each side of the index slot. FPTs are available with two dual-frequency options: 19 kHz and 12 kHz (part number F5Dp 19/12) or 12 kHz and 1.3 kHz (part number F5Dp 12/1.3). Like the other long range F5 transmitters, the FPT is 15 in. (38.1 cm) long and 1.25 in. (3.175 cm) in diameter, has a depth range of approximately 65 ft (19.8 m), and displays roll in 24 clock positions.



Long Range Fluid Pressure Transmitter (FPT)

For complete instructions on using the DataLog system for recording pressure-tension data, please see the [DigiTrak LWD DataLog System Operator's Manual](#).

For a list of all current DigiTrak Transmitters, see [Transmitter Selection](#) on page 28.

Batteries and Power On/Off

DCI battery-operated transmitters require two C-cell alkaline batteries, one DCI SuperCell lithium battery, or two lithium SAFT LSH14 batteries.

DCI extended long-range transmitters require one DCI SuperCell lithium battery. It is not practical to use alkaline batteries in extended long-range transmitters because they would only last a few hours.

The short-range FS transmitter requires one AA alkaline battery or one 1.5 V AA lithium battery.

Installing Batteries / Power On

DCI transmitters power on as soon as batteries are properly installed. To install the batteries:

1. Remove the battery cap from the transmitter by rotating the knurled cap counter-clockwise. On older transmitters, use a large slotted screwdriver to turn the cap.
2. Insert the battery or batteries into the transmitter with the positive terminals first. When using two C-cell batteries, include the battery contact spring that came with the transmitter as shown below.

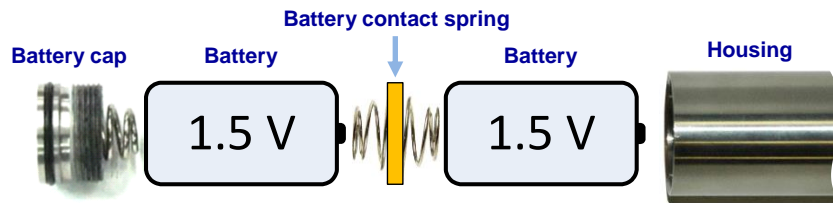

Alkaline Batteries Installed with Battery Contact Spring



Note Do NOT use the battery contact spring at either end of a single SuperCell™ battery.

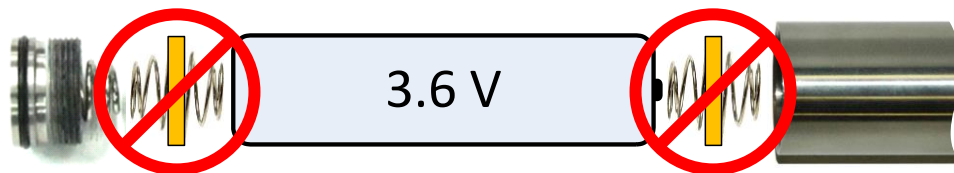

Select the frequency of a dual-frequency transmitter by installing the batteries with the transmitter pointing either up or down:

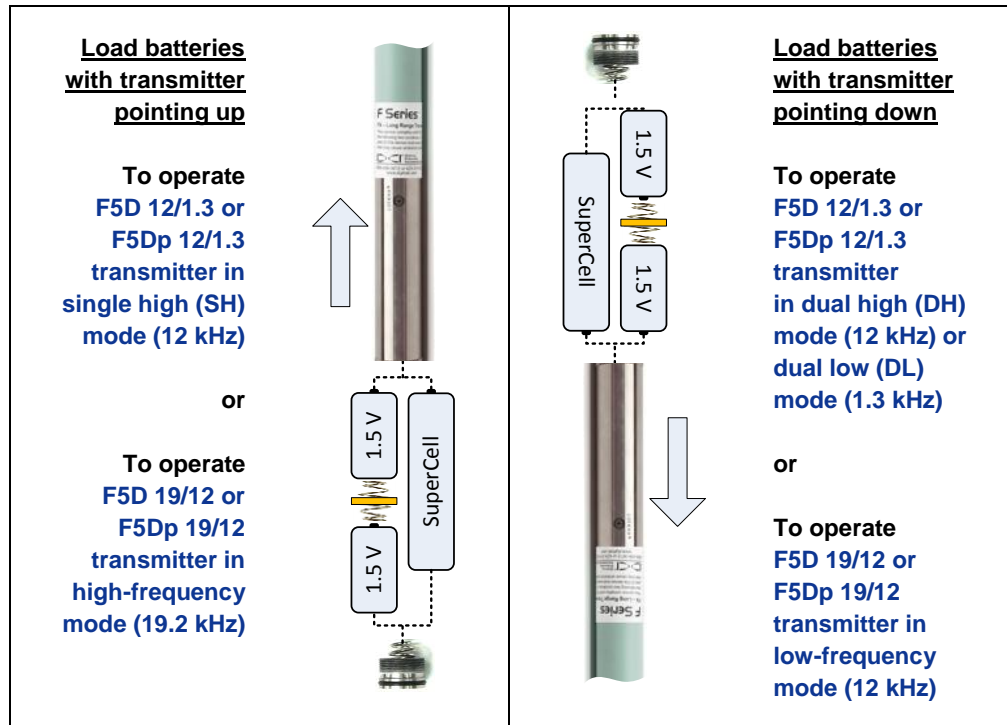

Setting the Frequency of Dual-Frequency Transmitters



Note The pressure sensor in an FPT (F5Dp 19/12 or F5Dp 12/1.3) will be set to zero when the transmitter powers up vertically. Powering up horizontally maintains the last frequency and pressure calibration.

3. After installing the batteries, replace the battery cap. Be sure to keep a dual-frequency transmitter in the correct orientation while replacing the battery cap.

When using a “19/12” dual-frequency transmitter (F5D 19/12 or F5Dp 19/12), you can change the frequency after batteries are installed (see [Changing the Frequency of a “19/12” Dual-Frequency Transmitter](#) on page 31). The “12/1.3” dual-frequency transmitters (F5D 12/1.3 and F5Dp 12/1.3) must be set to single (12 kHz) or dual mode (12/1.3 kHz) when batteries are installed.

Transmitter Battery Status

The battery status symbol at the bottom of the receiver’s depth mode screen indicates the battery life remaining for alkaline batteries.

Because the battery status for a SuperCell battery will appear full until just before it is fully depleted, you must track its hours of use. A SuperCell is rated for 70 hours, or 400 hours in sleep mode.

Sleep Mode (Automatic Shutdown) / Power Off

All battery-powered DigiTrak transmitters go into sleep mode and stop transmitting to conserve battery power if they are stationary for longer than 15 minutes. To awaken the transmitter, rotate the drill string a half turn; a transmitter will not awaken if it lands on the same roll position at which it went to sleep.

A small amount of charge will continue to drain from the batteries while the transmitter is in sleep mode. To conserve battery life, do not leave batteries in the transmitter when they can easily be removed, and always remove batteries when the transmitter is not being used.



Note A transmitter will continue sending data for up to 20 seconds after the batteries are removed. If you have removed the batteries and intend to restart the transmitter in another frequency, wait until data has stopped displaying on the receiver before reinstalling the batteries.

Transmitter Housing Requirements

For maximum transmitter range and battery life, the slots in the drill housing must meet minimum length and width requirements and be correctly positioned. DCI transmitters work best with slots that are equally spaced around the circumference of the housing for optimal signal emission and maximum battery life. The slots must be at least 1/16 in. (1.6 mm) wide. For accuracy, slot measurements must be taken from the inside of the housing.

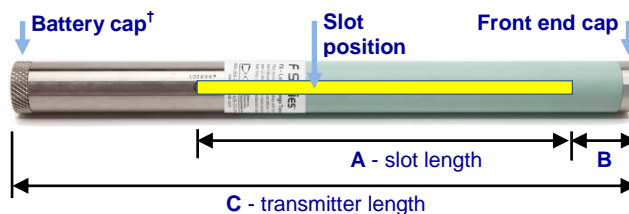

	A Minimum	B	C
Long Range HDT*	8.5 in. (21.6 cm)	2.0 in. (5.1 cm)	15 in. (38.1 cm)
Extended Range HDT	13.0 in. (33.0 cm)	2.0 in. (5.1 cm)	19 in. (48.26 cm)
Short Range FS	3.75 in. (9.5 cm)	1.25 in. (3.2 cm)	8 in. (20.32 cm)
Cable FC**	9.0 in. (22.9 cm)	2.5 in. (6.4 cm)	19 in. (48.26 cm)

* Long-range Fluid Pressure Transmitters (FPTs) have the same slot requirements but additional housing requirements; please contact DCI Customer Service for more information.

**The FC transmitter requires the use of the MFCB (multi-function cable box) system to operate. For more information and complete instructions, see the [MFCB Operator's Manual](#) available on our website.

A transmitter must fit snugly in its housing. It may be necessary to wrap the transmitter with tape or O-rings and/or to use a housing adapter for larger drill housings. Contact DCI Customer Service for more information.

The index slot in the front end cap of the transmitter should fit onto the anti-roll pin (key) in the housing for proper alignment. If the transmitter's 12 o'clock position will not match that of the drill head, you will need to [Set Roll Offset](#) (see page 55).

Transmitter Selection

For the receiver to detect the signal from the transmitter, the receiver and transmitter must have matching regional designation numbers (see [Receiver Startup Screen](#) image on page 7). The receiver must also be set to match the transmitter and frequency being used (discussed below) and calibrated to that transmitter (see [Calibrate Receiver to Transmitter](#) on page 50).

The transmitter selection icon  on the Main menu opens a window of transmitters available for use with the F5 system. If there is more than one option for a selection, a secondary menu will appear. Your receiver may display more or less transmitters than are shown on the following screen depending on its configuration and your region.

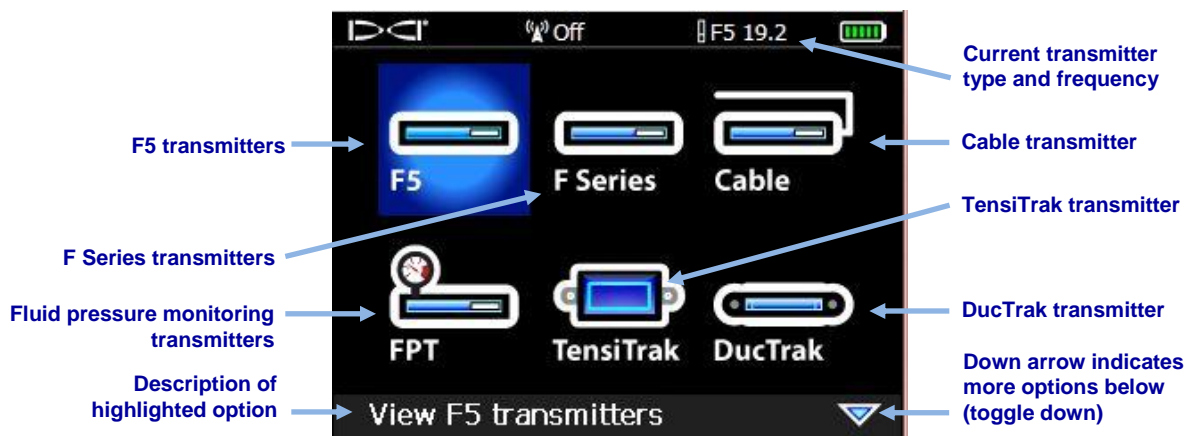

Transmitter Selection Menu



Note If you purchased a TensiTrak for monitoring and recording pullback pressure and tension, consult your TensiTrak owner's manual (available [online](#)) for additional information, as selecting TensiTrak will significantly change the appearance of the Locate Mode display screen.

Transmitter Shortcut Menu

To quickly change between frequencies of a dual-frequency transmitter on a receiver running software version 3.0 or later, hold the toggle switch right at the Locate Mode screen to open the Transmitter Shortcut menu.

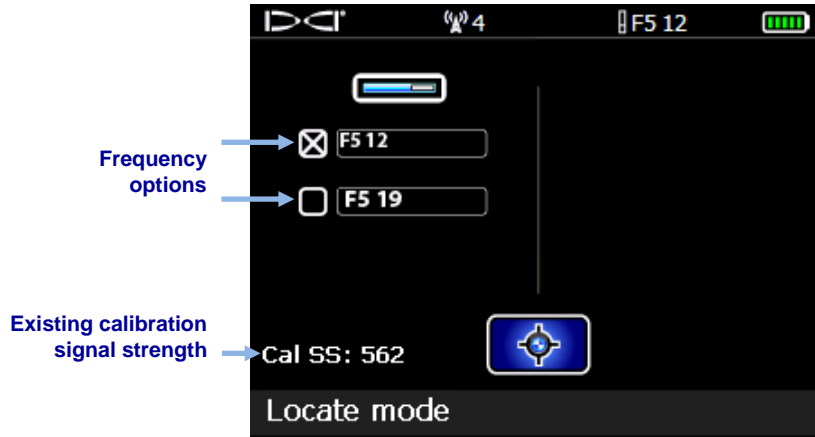

Transmitter Frequency Shortcut Menu

Select from the frequencies listed on the left. If only one frequency is listed, the transmitter in use is not dual-frequency. Select **Locate Mode**  to return to the Locate Mode screen.



















Transmitter Selection Menu Options

The available menu options for each type of transmitter are listed in the following table. For dual-frequency transmitters, the menu option icon shows the required orientation of the transmitter (pointing up or down) during battery insertion to power up the transmitter in the correct mode (see [Installing Batteries / Power On](#) on page 25).

If the selected transmitter type has more than one model option, as in the case of F5, F Series, Cable, and FPT transmitters, another screen appears to select the specific transmitter model. If a dual-frequency transmitter is selected, an additional screen appears to select the desired frequency.

After a transmitter selection, the display returns to the Main menu with the new transmitter type and frequency noted at the top right of the screen as shown above.

Transmitter Selection Menu Options

	Menu Option	PN/Model	Frequency
F5 Transmitters		PN: F5D 19/12 HDT	19.2 kHz
		PN: F5D 19/12 HDT	12 kHz
		PN: F5D 12/1.3 HDT	Single High (SH) at 12 kHz
		PN: F5D 12/1.3 HDT	Dual High (DH) at 12 kHz
		PN: F5D 12/1.3 HDT	Dual Low (DL) at 1.3 kHz
		PN: F5X 18 HDT	18.5 kHz
		PN: F5X 8 HDT	8.4 kHz
F Series		PN: FX 19 HDT PN: FXL 19.2 FXL 19.2	19.2 kHz
		PN: FX 12 HDT PN: FXL 12 FXL	12 kHz
		PN: FS FS	12 kHz
Fluid Pressure		PN: F5Dp 19/12 FPT	19.2 kHz
		PN: F5Dp 19/12 FPT	12 kHz
		PN: F5Dp 12/1.3 FPT	Single High (SH) at 12 kHz
		PN: F5Dp 12/1.3 FPT	Dual High (DH) at 12 kHz
		PN: F5Dp 12/1.3 FPT	Dual Low (DL) at 1.3 kHz
		PN: FC FC	12 kHz (cable)
Specialty		PN: DDS 12 DDS 12 PN: DDT 12 DDT 12	12 kHz
		PN: SST* SST	12 kHz
		PN: TT5* TT5	12 kHz

* Steering Tool (SST) and TensiTrak only appear if enabled on the receiver. Contact DCI Customer Service for more information.

Calibration is required every time you use a different transmitter, receiver, or housing. Calibration is not necessary, however, when switching between transmitters that were previously calibrated.

Changing the Frequency of a “19/12” Dual-Frequency Transmitter

The “19/12” dual-frequency transmitters (F5D 19/12 and F5Dp 19/12) can be used at either frequency (19.2 kHz or 12 kHz). After the transmitter has been powered on, the frequency setting of the transmitter can be changed two different ways: the pitch method is done with the transmitter above ground, while the roll method is done with the transmitter installed in the drill head and below ground.

Above Ground (Pre-Bore Pitch Method)

Do not roll the transmitter more than one clock position during this procedure.

1. Place the transmitter on an approximately level surface ($\pm 6.75^\circ$ or $\pm 15\%$) and ensure the receiver is in locate mode and transmitter data is being displayed.
2. Tilt the transmitter up so it has a pitch value of greater than 50° (over 100%, or nearly vertical).
3. Hold the transmitter steady for 10–18 seconds.
4. Slowly return the transmitter to level.
5. After about 10–18 seconds, all transmitter data disappears from the receiver’s screen, indicating the transmitter frequency has changed.
6. Select the new frequency in the receiver’s Transmitter Selection menu; the new frequency displays at the top of the screen. Open the Locate Mode screen and verify that transmitter data appears on the display.

Below Ground (Mid-Bore Roll Method)

1. Ensure that the roll offset function is disabled and transmitter roll data is displayed on the receiver.
2. Position the transmitter at 10 o’clock ($\pm 1/2$ clock position, or CP) for 10–18 seconds.
3. Slowly roll the transmitter clockwise to its 2 o’clock position ($\pm 1/2$ CP) and allow it to remain there for 10–18 seconds.
4. Slowly roll the transmitter clockwise to its 7 o’clock position ($\pm 1/2$ CP).
5. When transmitter data disappears from the receiver, the transmitter frequency has changed. This will take approximately 10–18 seconds.
6. Select the new frequency in the transmitter selection menu; the new frequency displays at the top of the screen. Open the Locate Mode screen and verify that transmitter data appears on the display.



Note If you must disable the roll offset function before changing frequencies, note the transmitter’s uncompensated roll position when the drill head is at its 12 o’clock position. After a successful frequency change, rotate the drill head so the roll position of the transmitter shows the noted value and re-enable roll offset.

Temperature Status and Overheat Indicator

All DigiTrak transmitters are equipped with an internal digital thermometer. The temperature displays on the bottom right of the receiver and remote display screens next to the transmitter temperature symbol . Normal drilling temperatures range from 64° F (16° C) to 104° F (40° C). Suspend drilling when temperatures exceed 95° F (35° C) to permit cooling.



Note Because the digital thermometer is inside the transmitter, temperature increases due to external drilling conditions will take time to transfer to the transmitter. Resolve increases in temperature quickly to avoid irreversible damage.

If the temperature reaches 118° F (48° C), the transmitter is becoming dangerously hot. The thermometer icon will change to show that the transmitter is reaching a dangerous temperature, . The transmitter must be allowed to cool immediately or it will be damaged.

To cool the transmitter, stop drilling and retract the drill bit a few feet and/or add more drilling fluid.

Transmitter Temperature Warning Tones

The F5 receiver and remote display emit the following audible tones to indicate increases in the transmitter temperature:

Temperature	Warning Tones
Below 61° F (16° C)	None
61–97° F (16–36° C)	Double-beep sequence (beep-beep) for every 4° C increase in temperature.
104–111° F (40–44° C)	Two double-beep sequences (beep-beep, beep-beep) for every 4° C increase in temperature. Action is required to cool the transmitter.
118–133° F (48–56° C)	Three double-beep sequences (beep-beep, beep-beep, beep-beep) for every 4° C increase in temperature. Cooling is critical to avoid irreversible damage.
Above 140° F (60° C)	Three double-beep sequences every 5 seconds on the remote display, and every 20 seconds on the receiver. This warning signifies dangerous drilling conditions; irreversible damage may have already been done.
Above 176° F (80° C)	None: transmitter shuts down.
180° F (82° C)	None: FS and FC transmitter overheat indicator (temp dot) turns black (see next section).
220° F (104° C)	None: Long-range and extended long-range transmitter overheat indicator (temp dot) turns black (see next section).

Transmitter Overheat Indicator (Temp Dot)

Each transmitter has a temperature overheat indicator (temp dot) on the front end cap. The temp dot has an outer yellow ring with a $\frac{1}{8}$ in. (3 mm) white dot in the center. The white dot will change color if the transmitter is exposed to excessive heat.



Transmitter Temp Dot

If the temp dot changes to silver or gray, the transmitter has been exposed to heat but not in excess of specifications. If the temp dot is black, the transmitter has been exposed to excessive temperatures (over 220° F/104° C for long range and extended range transmitters and 180° F/82° C for an FS or FC transmitter) and can no longer be used. The DCI warranty does not cover any transmitter that has been overheated (black dot) or had its temp dot removed.

Avoid transmitter overheating by practicing proper drilling techniques. Abrasive soils, clogged jets, inadequate mud flow, and poorly mixed mud all contribute significantly to the overheating of a transmitter.

Remote Display

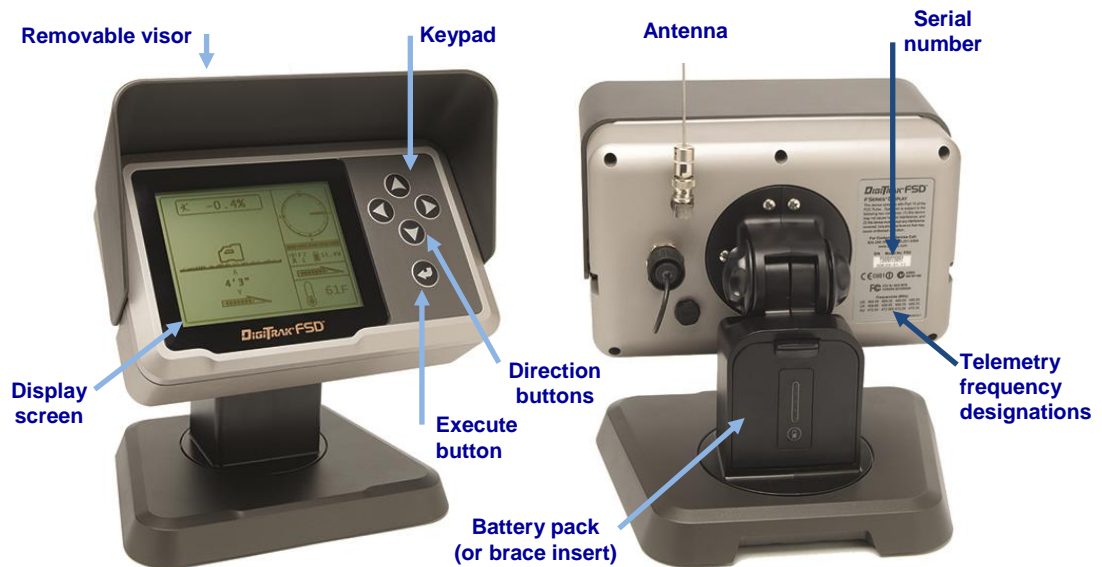

DigiTrak F Series Display (FSD) Front and Back

General Description

The DigiTrak F Series Display (FSD) is a multifunction remote display used with a variety of DigiTrak receivers. It provides the drill rig operator with information from the F5 receiver about the depth, orientation, and status of the transmitter. The FSD remote can be powered through either a DC cable source or an F Series battery pack.

An external 13 in. (33 cm) telemetry antenna is supplied with the FSD to enhance signal reception up to 1800 ft (550 m) with line of sight to the receiver.

To meet regional requirements and for proper communication, one of the telemetry frequency designations shown on the remote's serial number label must match the one shown on the F5 receiver. The receiver's telemetry frequency designation is located on the serial number label inside the battery compartment (see [Receiver](#) on page 5).

The FSD has an internal speaker that beeps at startup and emits warning tones when the transmitter temperature increases. See [Transmitter Temperature Warning Tones](#) on page 32 for a complete listing of the warning tones and what they signify.

Power Options

Installing the Battery Pack or Brace Insert

Hold the battery pack with the tab facing up and away from the FSD remote, then insert it into the battery compartment and push in until the tab latches in place.

To remove the battery pack, push down on the battery tab and pull it away from the remote until the tab is released.

Connecting the DC Power Cable

The DC power port and DC power cable connector are keyed for proper alignment. To connect the power cable, remove the protective cap from the power port on the back of the remote, align the key marks in the connector with the key slots in the power port, and push in and rotate the connector clockwise until the connector locks into place. Connect the other end of the DC cable to a DC power source.

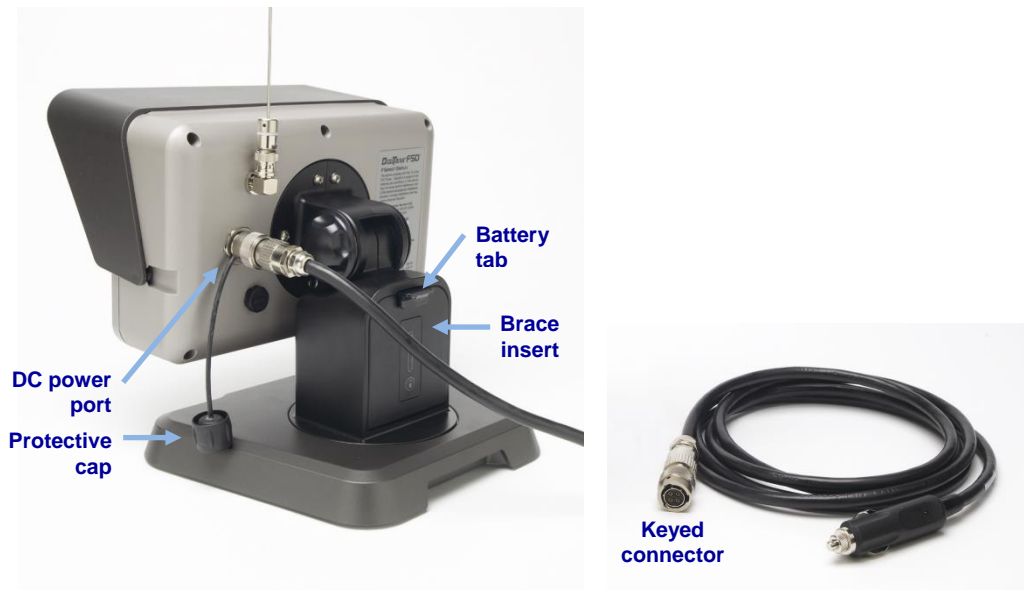



DC Power Cable (right) and Brace Insert Installed in FSD Remote

When powering the FSD with DC power, install the brace insert in the battery compartment for structural integrity. Install and remove it in the same manner as the battery pack.



Note If both a battery pack and the DC cable are connected at the same time, the remote will draw power from the battery until its voltage is below the DC source voltage.

Powering On and Off

Power on the FSD by pressing the Execute button  for about two seconds. A tone sounds and the [Main Menu](#) appears (see page 37). Power off the FSD by selecting Power Off  from the Main menu, then holding the Execute button.

Keypad

Use the keypad to the right of the display window to operate the FSD remote.

Execute Button

Use to turn on the FSD unit, select a highlighted menu option, adjust contrast, and execute menu options. It functions like the trigger switch on the F5 receiver.



Arrow Buttons

Use to navigate through menu options. Use the down arrow to access the Main menu from the remote mode. The arrow buttons function like the toggle switch on the F5 receiver.



Viewing Angle and Visor

The FSD viewing angle adjusts on three axis.

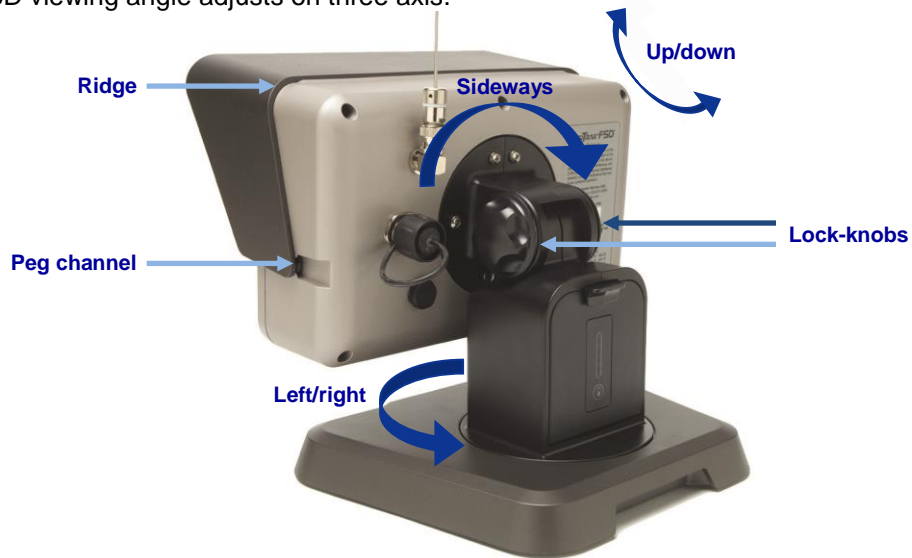

Viewing Angle Adjustments

To adjust the vertical angle, loosen and then squeeze the two lock-knobs on the back of the remote display, adjust the screen, and retighten. If the lock-knobs are loose, the display may not hold its vertical position during drilling.

To adjust the horizontal angle, simply rotate the display in the base.

The display will also rotate sideways in the event you need to mount it to a vertical surface. If so, loosen the two lock-knobs and angle the screen out slightly before rotating so it clears the base.



Caution Adjusting the up/down orientation of the display without loosening the lock-knobs can damage the unit.

The removable visor on the FSD helps with both sun and rain. The visor is held in place by a ridge on the top and channels on the sides of the display. To install the visor, slide the pegs on the visor along the peg channels on the sides of the display until the visor locks over the ridge. To remove the visor, push the visor back over the ridge and along the channels, or simply rotate it back and out of the way.

Main Menu

Access the Main menu by pressing the down arrow. The Remote Mode option is automatically highlighted.

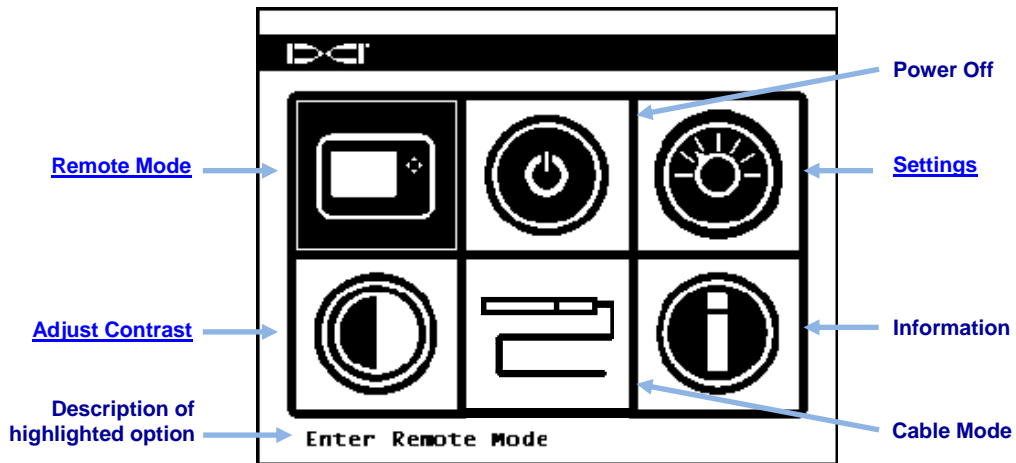

FSD Main Menu

Use the arrow buttons to highlight an option, then press the execute button to select it. The options available on the Main menu are described below and in the following sections.

- Cable Mode** Enables use of an FC cable or SST transmitter.
- Information** Displays FSD system information such as the software version, serial number, telemetry configuration, and current settings.

Remote Mode

Remote Mode opens the Remote Mode locating screen, which is the default screen displayed on startup. It shows the transmitter pitch, roll, battery status, depth, predicted depth, and temperature. The main screen also shows the FSD battery status, receiver type, telemetry channel, telemetry update meter, and Target Steering data (if active). To reach the Main menu, press the down arrow .

For detailed information about the Remote Mode locating screen and the depth display screens, see [Display Screens](#) on page 39.

Settings

The Settings menu lets you change the settings shown below:

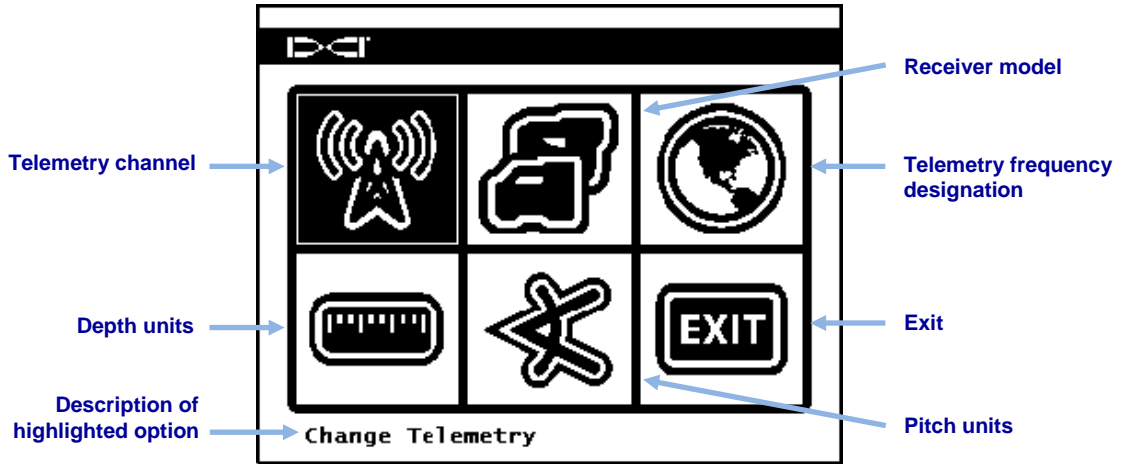

FSD Settings Menu

DCI recommends that you set the FSD to use the same settings, such as degrees or percent of slope, as those on the F5 receiver.

- Telemetry Channel** Select between telemetry channel options 1, 2, 3, and 4. The remote and the receiver must be set to the same channel and must have the same telemetry frequency designation.

- Receiver Model** Set the FSD unit to work with select DigiTrak receivers. Operator's manuals for other receivers are available on Digital Control's website at www.digitrak.com.

- Telemetry Frequency Designation** Before changing telemetry region, contact DCI to determine which setting is required in your area and to verify that it matches the receiver's telemetry frequency designation.





- Depth Units** Set depth units as either English (Fahrenheit, psi, and lbs.) or metric (Celsius, kPa, and kN).

- Pitch Units** Set pitch angle units as either percent (%) or degree (°).

- Exit** Exits to the Main menu. If a setting was changed, the exit option is automatically highlighted.

Adjust Contrast

To adjust contrast, hold the execute button  while pushing the right or left arrows to lighten or darken the display, respectively.

Alternatively, select Adjust Contrast  on the Main menu, use the left or right arrow on the FSD to select either Decrease Contrast  or Increase Contrast , then press Execute  repeatedly to change the contrast incrementally. To save the settings, use the left/right arrows on the FSD to highlight the curved arrow on the screen, then press Execute to save and return to the Main menu.

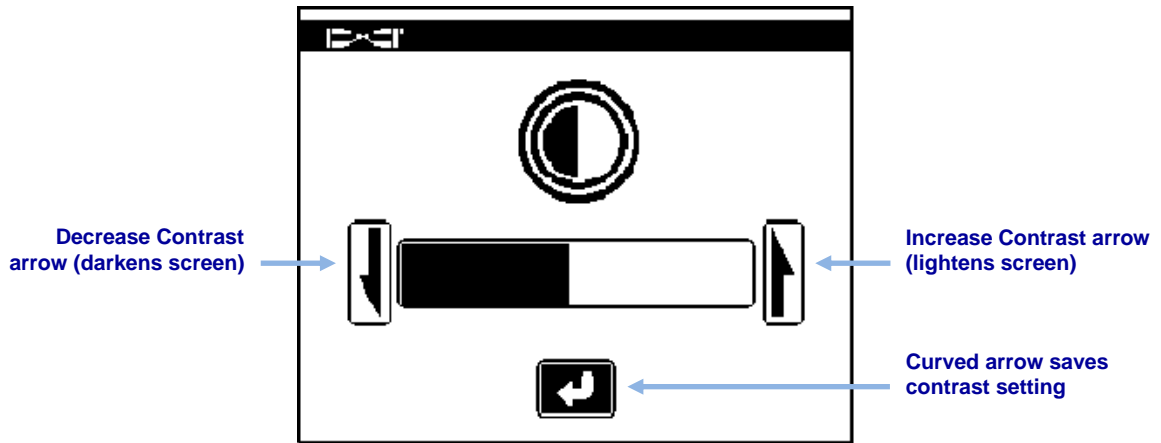

Adjust Screen Contrast

Display Screens

Remote Mode Locating Screen

The Remote Mode locating screen is the default screen displayed on startup. It shows the transmitter pitch, roll, battery status, depth, predicted depth, and temperature. It also shows the FSD battery status, receiver type, telemetry channel, telemetry update meter, and Target Steering data (if active). To return to the Main menu, press the down arrow.

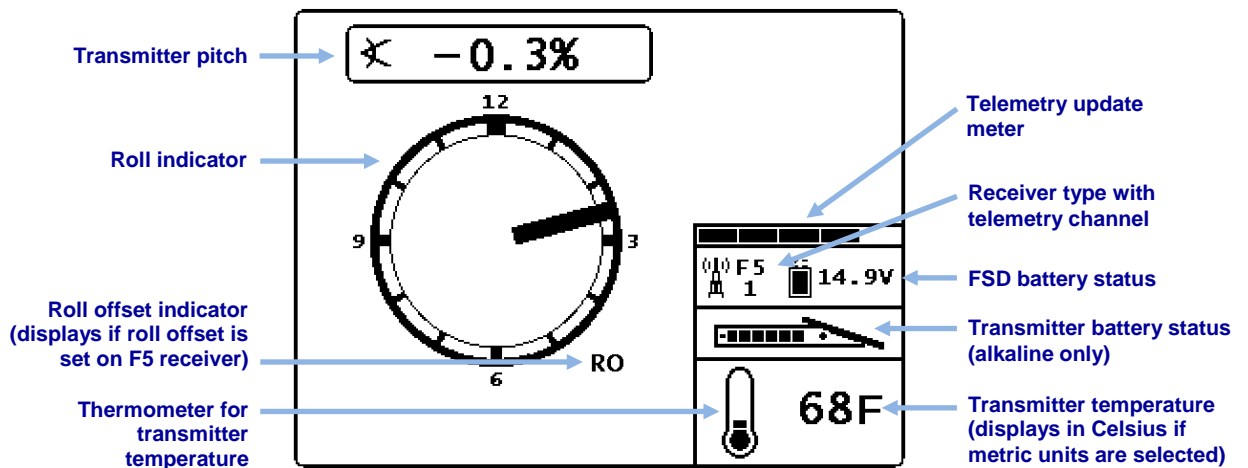

FSD Remote Mode Locating Screen

The telemetry update meter displays the amount of signal being received. If less data is being received, then fewer bars are shown on the meter. If the meter is decreasing or low, ensure you have correct data before making steering decisions. When the meter is empty, no telemetry data is being received and all transmitter information will disappear.

If the roll offset function is set on the receiver (an electronic compensation to match the transmitter's 12 o'clock position to that of the tool), RO displays at the bottom right of the roll indicator. For more information, see [Set Roll Offset](#) on page 55.

If a fluid pressure transmitter is used, the instantaneous fluid pressure will show in place of the transmitter battery status on the screen above. The transmitter battery status will still show on the depth display screen (see next section). When using a fluid pressure transmitter, if the pressure exceeds the overload condition of 250 psi (1725 kPa), the pressure will display as 255 psi (1760 kPa).

Depth Screen

The depth or predicted depth of the transmitter can be viewed on the remote display, but only when the receiver is positioned at the locate line (LL) or at the front locate point (FLP) with its trigger held in. See [Locate Points \(FLP & RLP\) and Locate Line \(LL\)](#) on page 60 for information on correctly positioning the receiver.

When the receiver is positioned at the LL with the trigger held in, the FSD display will change to show the depth reading, with arrows pointing to the ground and drill head. When the height-above-ground function (HAG) is turned on, the receiver icon is shown elevated above the ground with the HAG setting displayed. The following figure shows the HAG setting at 2' 03". For more information on the HAG settings, see [Set Height-Above-Ground \(HAG\) Distance](#) on page 57.

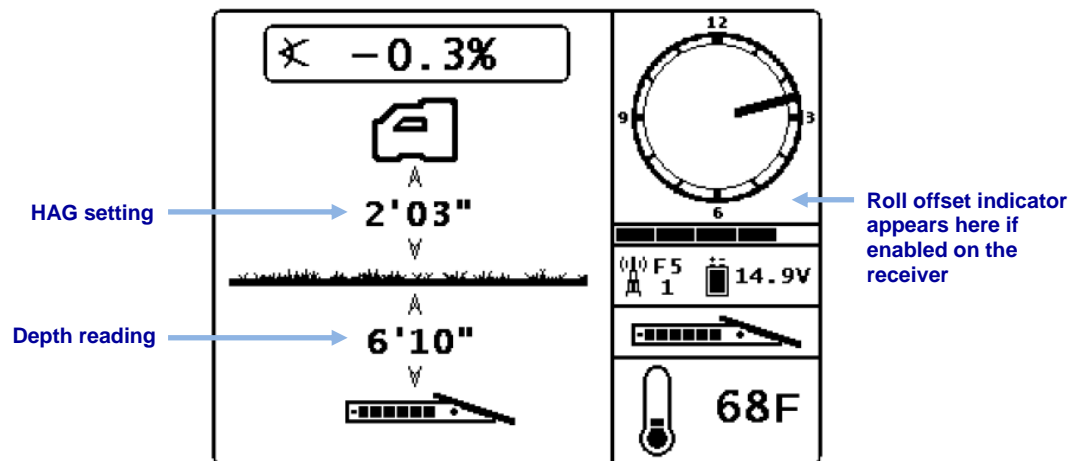

FSD Depth Display at Locate Line with HAG On

The depth will display for 10 seconds after the trigger on the receiver is released, then the display returns to the Remote Mode locating screen.

When a roll offset is set at the receiver, the letters RO will display at the bottom right of the transmitter roll indicator on the depth display and on the predicted depth display. For more information, see [Set Roll Offset](#) on page 55.

Predicted Depth Screen

The predicted depth screen appears when the receiver is positioned at the front or rear locate point (FLP or RLP) with the trigger held in. However, the predicted depth is only valid at the FLP. The predicted depth display will show arrows pointing to the receiver and the predicted depth point ahead of the transmitter. For more information about predicted depth, see [Locating](#) on page 59.

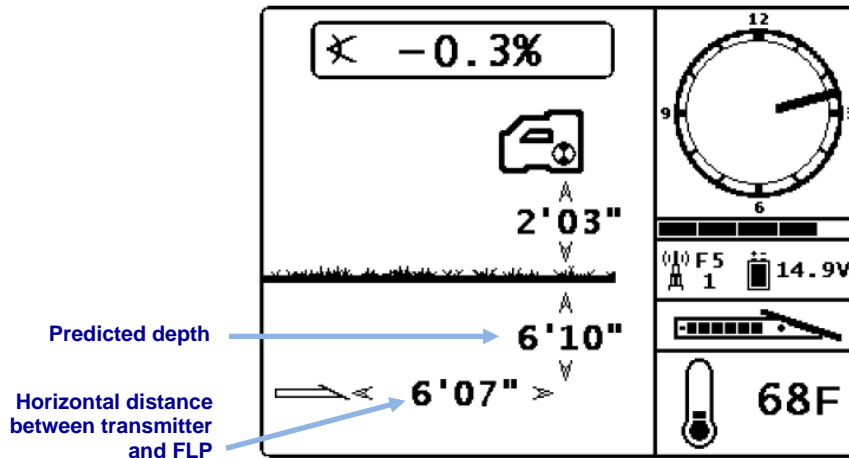

FSD Predicted Depth Display with HAG On

As on the normal Locate Mode screen, when a roll offset is set at the receiver, the letters RO will display at the bottom right of the roll indicator. The example shown above shows no roll offset has been set.

When the transmitter pitch information cannot be obtained at the receiver due to range restrictions or interference, the remote will assume the transmitter has a pitch of zero for depth and predicted depth readings. In this case, the remote will show the transmitter pitch as .

Battery Charger



F Series Battery Charger System

General Description

The DigiTrak F Series Battery Charger (FBC) system includes AC and DC power cords, an AC adapter, and three rechargeable F Series battery packs (FBP). The battery packs power both the F5 receiver and the FSD remote. The FBC battery charger can operate from AC (100–240 V, 50–60 Hz, 1.5 A max.) or DC (10–28 V, 5 A max.) power sources. The AC power cord provided with your system is standard to your global area of operation.

A fully charged lithium-ion F Series FBP will power an F5 receiver for approximately 10 hours or an FSD remote for approximately 14 hours before recharging is necessary. A battery pack can be recharged about 400 times before the battery life is substantially reduced.

Checking Battery Status

To check the charge status of a battery pack at any time, press the battery status button below the five LEDs. The LEDs indicate the charge level, with each representing 20% of the charge.



F Series Battery Pack

Installing and Removing the Battery Pack

Insert a fully charged DigiTrak F Series battery pack so it is flush with the back of the receiver and the tab is securely latched. To remove the battery pack, push down on the battery tab and pull the battery pack out and up from the battery compartment.

AC/DC Power Setup

Install either the AC adapter or the DC power cord by inserting the charger plug into the power port of the battery charger and then rotating it a quarter turn in either direction to lock it in place.

If using AC power, connect the AC power cord to the AC adapter, then plug the adapter into an AC power receptacle. If using DC power, plug the DC power cord directly into the DC power source. Once powered, the LEDs on the battery charger will begin to flash in succession and the charger will emit a series of beeps.



Inserting Charger Plug into Power Port

Charging a Battery Pack

With the charger connected to a power source and the orange LED flashing, insert a battery pack. The battery pack will be flush with the battery charger when it is properly inserted. The charger will emit a long tone followed by four short beeps indicating an F Series battery pack has been detected.

During normal charging, the orange and red LEDs will illuminate to indicate the battery pack is undergoing a fast charge cycle. The battery pack is fully charged when the orange and green LEDs flash alternately.



Note F Series battery charger systems labeled for use with DCI Li-ion or NiMH battery packs will also charge SE NiMH battery packs (SBP), although the charging times, battery voltages, and estimated battery lifetimes will be different from F Series Li-ion battery packs.

Battery Charger Status Indicators

The battery charger has red, orange, and green LEDs that are on, off, or flashing depending on the charging status. A series of beeps will also sound to indicate a major battery pack or charger fault. The following table describes the charger or battery status indicated by the various LEDs and audible signals.

LEDs and Audible Signals	Charger or Battery Pack Status	Status Description	Action
Flashing Orange	No Battery Pack Detected	No battery pack or unknown battery type detected.	Insert viable battery pack.
Solid Green & Solid Orange	Slow Charge / Voltage Restoration	Battery pack voltage is less than 11.0 V, or Battery pack temperature is above 104° F (40° C).	None. Charger will slowly restore battery pack to full voltage.
Flashing Green & Solid Orange	Minor Charger Fault	Fault detected within charger temperature sensor circuitry.	Charger is safe to use temporarily with charge current limited to less than 1.0 A, but it should be sent in for repair as soon as convenient.
Solid Orange & Solid Red	Fast Charge	Normal operation; charge duration is approximately 4 hours.	None.
Alternately Flashing Green & Orange	Full Charge	Battery pack is charged to 100% capacity.	Remove fully charged battery pack.
Alternately Flashing Green & Red	Charge Terminated	Over-discharged battery pack could not be revived within a reasonable amount of time, or battery pack is in an over-charged condition.	Battery pack is damaged or near the end of its useable life. If battery pack is fairly new and in good physical condition, contact DCI Customer Service. Otherwise, battery pack is unrecoverable and should be properly recycled.
Alternately Flashing Orange & Red with Series of Beeps	Battery Pack Temperature Fault	Battery pack temperature is above 122° F (50° C), or battery pack temperature is below 32° F (0° C).	If battery pack is hot, try to cool it down; if cold, try to warm it up. Then recharge battery pack.
Flashing Red with Series of Beeps	Permanent Battery Pack Fault	Battery pack voltage is less than 5.0 V.	Battery pack is unrecoverable and should be properly recycled.
Flashing Green , Orange & Red with Series of Beeps	Major Charger Fault	Unrecoverable hardware failure of charger electronics detected.	Stop using charger and send it in for repair immediately; please contact DCI Customer Service.

Warnings and Precautions

DCI assumes no liability for problems that occur when you do not follow these warnings and precautions, as well as the general precautions outlined in [Safety Precautions and Warnings](#) on page 1.



Warning The charger is designed with adequate safeguards to protect you from shock and other hazards when used as specified within this manual. If you use the charger in a manner not specified by this document, the protection provided by the charger may be impaired. Please read this manual before using the charger.



Warning If you transport the charger in checked baggage, be sure to remove the batteries from the charger before packing it.

Temperature

The temperature of the air around the battery charger should be between 32 to 95° F (0 to 35° C). Charging the battery outside this range may increase charge time, harm battery performance, or reduce battery life.

It is important to maintain free airflow around the charger, especially near the top and bottom vents.

If the battery's internal temperature is below 32° F (0° C) or above 122° F (50° C), the charger will not deliver charge current and will indicate a temperature fault.

Power Input

Use the supplied AC adapter and power cord or DC power cord to power the charger with DC power in the specified voltage range. Using other power cables could damage the charger, void the warranty, and cause a safety hazard.

User Serviceability

Do not disassemble the charger. It contains no user-serviceable parts.

Liquids

Avoid spilling liquids on the charger, which could cause a short circuit it. If liquids are accidentally spilled on the charger, send it to DCI for repair.

Battery Disposal

All DCI lithium-ion batteries are classified by the United States federal government as non-hazardous waste and are safe for disposal in the normal municipal waste stream. These batteries, however, do contain recyclable materials and are accepted for recycling by the Rechargeable Battery Recycling Corporation's (RBRC) Battery Recycling Program. Please call 1-800-8-BATTERY or go to the RBRC website at www.rbrc.org or information on recycling your used battery.

Getting Started



This section details the basic steps required to prepare the F5 system for locating. These steps include:

- Power on the receiver, remote display, and transmitter (next section)
- Conduct interference check (page 47)
- Calibrate receiver to transmitter and/or verify calibration (page 50)
- Set roll offset, if required (page 56)
- Set height-above-ground (HAG) distance, if desired (page 57)

Additional steps are required when using the drill DataLog or pressure-tension DataLog function (Log-While-Drilling, LWD), the F5 TensiTrak system pullback and pressure monitoring system, or a cable transmitter. Manuals for LWD, TensiTrak, and the Multi-Function Cable Box (MFCB) used with cable transmitters are available on our [website](#).

Power on Receiver, Remote Display, and Transmitter

Receiver



1. Before loading a battery pack, note the telemetry frequency designations listed on the serial number label inside the battery compartment.
2. Install a fully charged battery pack.
3. Turn on the receiver by holding in the trigger switch briefly.
4. Click the trigger to accept the “Read the manual before using” statement.
5. Note the regional designation number in the globe  on the receiver startup screen. This number must match that of the transmitter.
6. Click the trigger to display the Main menu.
7. From the Main menu, select the Settings menu.
8. Use the Settings menu  to set the depth units, pitch units, time and calendar, telemetry channel, pressure units, temperature units, and force units, as needed.

Remote Display

1. Compare the telemetry frequency designations listed on the back of the remote display with the numbers from the receiver’s serial number label. If they don’t match, contact DCI Customer Service.
2. Install a fully charged battery pack or connect the DC power cable and install the brace insert in the battery compartment.
3. Press the execute button to turn on the remote, which starts at the Remote Mode locating screen
4. Press the down arrow to display the Main menu.

5. From the Main menu, select the Settings menu  to set the depth units, pitch units, and telemetry channel. Ensure you use the same settings here as you are on the receiver. You should also use the same system of units (English or metric) on both devices.

Transmitter

1. Compare the regional designation number in the globe  on the transmitter with the number on the receiver's serial number label. If they don't match, contact DCI Customer Service.
2. See [Installing Batteries / Power On](#) on page 25 for instructions on how to install batteries so the transmitter powers on in the preferred frequency.
3. Using the transmitter selection menu  on the F5, set the receiver to detect the type and frequency of the transmitter (see [Transmitter Selection](#) on page 28).

Conduct Interference Check

What Interference Is and How to Check for It

Before drilling (preferably before bidding on a project), evaluate the interference potential at the job site. Interference can reduce the transmitter's range or cause variable readings and possibly result in job slowdowns. Interference is classified as either *active* and *passive*.



Active interference, also known as electrical interference or background noise, can have varying effects on F5 locating equipment. Most electrical devices emit signals that can inhibit the ability to locate the transmitter accurately or get good pitch/roll readings. Some examples of active interference include traffic signal loops, buried dog fences, cathodic protection, radio communications, microwave towers, cable TV, fiber-trace lines, utility data transmissions, security systems, power lines, and phone lines. The following section describes how to use the F5 receiver to test for the presence of background noise.

Passive interference can reduce the amount of signal received from the transmitter, which results in deeper-than-expected depth readings or a completely blocked signal. Examples of passive interference include metal objects such as pipes, rebar, trench plate, chain-link fence, and vehicles. Two other examples are saltwater/salt domes and conductive earth, such as iron ore. The F5 cannot test for the presence of passive interference. Conducting a thorough site investigation prior to drilling is the best method of identifying passive interference sources.

To familiarize yourself with the interference potential along your intended bore path, first conduct a background noise check, then verify the speed and accuracy of the roll and pitch information.

Interference Noise Check

The background noise (interference) along a bore path should generally be at least 150 points less than what the transmitter's signal strength was when measured at the maximum depth for that bore. The Interference Noise Check feature simplifies the process used to evaluate background noise and select a transmitter frequency without having to walk the bore path with pen and paper in hand.

From the Main menu, select Diagnostics , then Interference Noise Check  (INC). While you walk the bore path with the receiver in this mode and the transmitter off, INC plots signal strength readings on a graph in real time. Take note of where background noise changes.

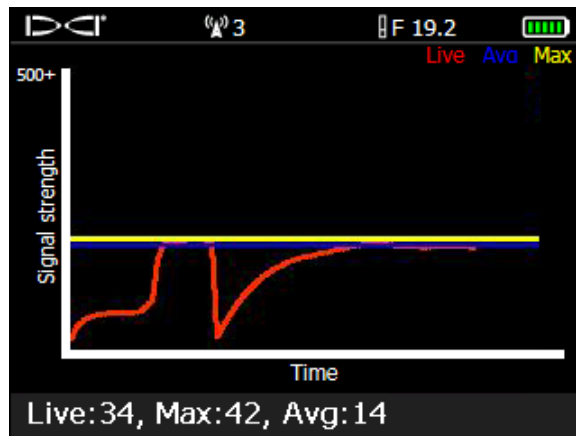

Sample Interference Noise Check Graph

The F5 receiver clears prior readings when INC begins, making it convenient to walk a bore path out in F5 12 KHz, note the areas of high interference, then select F5 19KHz and walk it back. The receiver takes about eight readings per second, averaging and drawing one data point every second. The graph displays about 4.5 minutes of data before the oldest data begins dropping off the screen as new data arrives.

The lines on the graph indicate the following:

- Red** Live signal strength readings
- Yellow** Maximum signal strength value encountered
- Blue** Running average of approximately the last 25 signal strength readings. This reading helps filter out small interference blips. If this line trends high, however, interference may be consistently high.

Toggle down to return to the Diagnostics menu.

In the following figure, the red flag area denotes an increase in background noise.

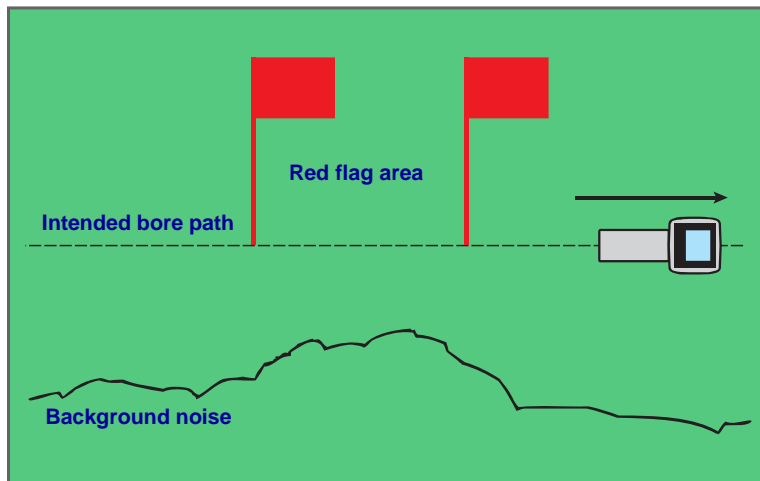

One-Person Background Signal Strength Check (No Transmitter)

Areas where the background noise level is too high may make it difficult to obtain roll and pitch data. Options include working in a different frequency (see page 31), off-track locating to avoid localized interference (see page 70), and using a cabled transmitter (see page 23).

Roll/Pitch Check

At the end of the bore path, turn the receiver to face the launch end and install batteries in the transmitter to turn it on. Have a coworker hold the transmitter and stand beside you at a distance of the approximate maximum depth of your intended bore. Walk together in parallel back toward the launch end, keeping the receiver over the bore path and the separation distance constant. Periodically stop and have your coworker change the transmitter's pitch and roll orientation so you can verify the speed and accuracy of these readings on the receiver. Note any locations where the display information becomes erratic or disappears.

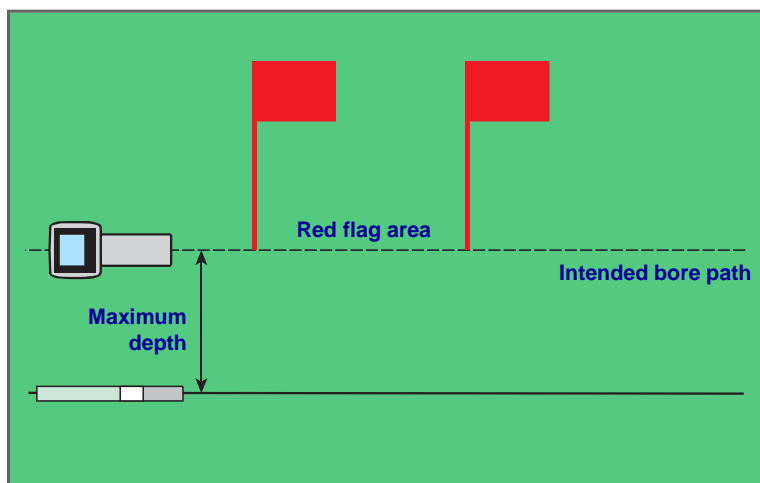

Two-Person Roll/Pitch Test with Transmitter



Note Electrical interference is determined by observing the signal strength with the transmitter turned on and then with the transmitter turned off. If the difference between these numbers is less than 150, electrical interference is excessive.

Suggestions for Dealing with Interference

If pitch/roll information becomes erratic or is lost, move the receiver away from the interference source while staying within range of the transmitter. Separation (use of the HAG function; see page 57) of the receiver from both passive and active interference is known to reduce or eliminate interference-related problems.

Another option is to use a transmitter with a different frequency or greater depth range. A transmitter with greater depth range has more power to overcome interference. A different frequency transmitter may have less interference potential on a given jobsite. To determine which transmitter is the best option, perform a background check using different transmitters and frequencies to see which provides the best signal for overcoming interference.

Calibrate Receiver to Transmitter

The receiver must be calibrated to the transmitter prior to first-time use and each time a different transmitter, receiver, or drill head is used. *The transmitter must be installed in a drill housing during the calibration procedure.* For information on how to first select the transmitter, see [Transmitter Selection](#) on page 28.

There are two calibration options: 1-point calibration (with the transmitter above ground) and 2-point calibration (with the transmitter below ground). The preferred method is 1-point calibration. The 2-point method is rarely needed and should only be used with caution. Both methods are described below, and both require a tape measure.



Note When using a “12/1.3” dual-frequency transmitter (F5D 12/1.3 or F5Dp 12/1.3), you only need to calibrate under one of the dual options, DH or DL, for both dual frequencies, 12 kHz and 1.3 kHz, to be calibrated. Verify the depth reading at two distances in both frequencies before drilling. If using single high (SH) mode, you must calibrate separately.

Select Calibration  from the Main menu. The calibration option previously used is automatically highlighted.



Receiver Calibration Menu

To cancel the calibration procedure, toggle to and click Exit. The display will return to the Main menu with no change to the calibration.



Note DCI does not recommend calibrating every day, but do verify the receiver's depth reading daily at different distances using a tape measure.

Do not calibrate if:

- You are within 10 ft (3 m) of metal structures, such as steel pipe, chain-link fence, metal siding, construction equipment, automobiles, etc.
- The receiver is over rebar or underground utilities.
- The receiver is in the vicinity of excessive electrical interference.
- The signal strength from the transmitter is less than 300 points (too low) or greater than 950 points (too high). If the signal is not within the specified range during calibration, a calibration failure screen will display indicating low or high signal strength, as shown below.



Too Low

Too High

Calibration Failure Screen – Signal Strength

Click the trigger to retry the calibration or select exit and return to the Main menu. If the calibration failure screen appears, verify your setup and try again or contact DCI Customer Service.

The transmitter must be installed in a drill housing during the calibration procedure.

1-Point Calibration (Above Ground)

1. Place the receiver and the transmitter (in a housing) on level ground, with both devices powered up. They must be parallel to each other and spaced 10 ft (3 m) apart. Use a tape measure to ensure the distance is 10 ft (3 m) from the center of the transmitter to the inside edge of the receiver, as shown below on the calibration screen.
2. With the receiver in locate mode, verify that roll and pitch values are being displayed and that a steady signal is being received from the transmitter. Record the transmitter's signal strength at the calibration distance (10 ft or 3 m) so it can be compared to future signal strength values. A change in signal strength can indicate you are currently in an interference environment or there is a problem with your equipment.
3. From the Main menu, select Calibration, then 1-point calibration .

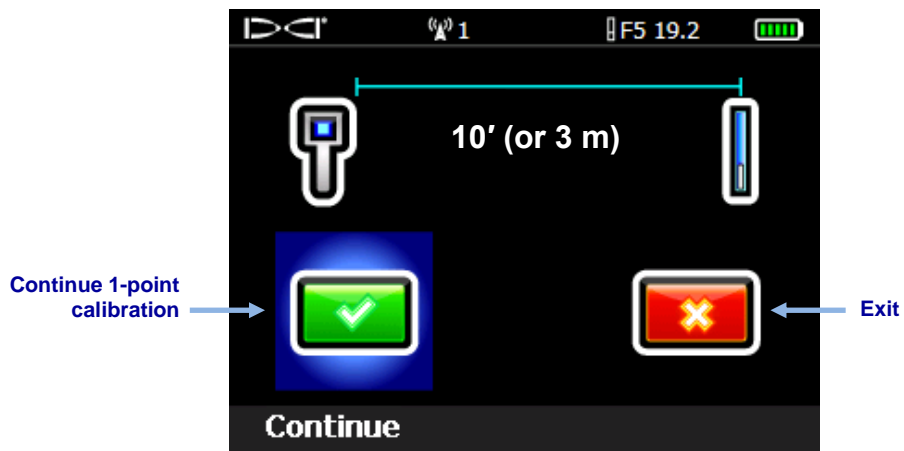

1-Point Calibration Screen

4. Click the trigger on Continue to initiate calibration. The screen will show that the receiver is calibrating. Do not move the receiver.

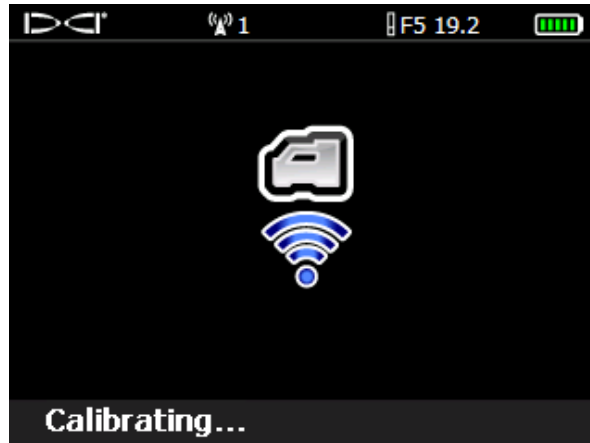

Calibration-In-Progress Screen

5. When calibration is complete, the receiver beeps four times and a checkmark displays on the screen, indicating a successful calibration. The screen will then return to the Locate Mode screen. If calibration fails, two long beeps will sound and the calibration failure screen will display. Verify the setup and try again or call DCI Customer Service.

After successfully completing the 1-point calibration procedure, take a depth measurement with the transmitter and receiver in the same orientation as during calibration. The depth should be 10 ft ± 5 in. (or 3 m ± 15 cm). Take another depth reading at some other measured distance and verify that the depth reading on the display remains accurate.

If necessary, turn Height Above Ground (HAG) back on. See [Set Height-Above-Ground \(HAG\) Distance](#) on page 57 for more information.



Note If depth data does not display, hold the trigger while over the transmitter to display the locate line. For additional information on obtaining this reference lock ("R"), see step 5 in the discussion under [Finding the Front Locate Point \(FLP\)](#) beginning on page 63.

2-Point Calibration (In Ground)

The 2-point calibration procedure is rarely needed. It requires you to obtain two calibration points, one with the receiver placed on the ground and one with the receiver raised 3 ft (or 1 m) above the ground. If you must calibrate with the transmitter in the ground, use this procedure with caution.



1. With the receiver in locate mode, position the receiver directly above an approximately level transmitter (see Locating on page 59 for instructions on aligning the receiver directly above the transmitter and ensuring the transmitter is level).
2. Verify that the signal strength readings with the receiver on the ground and raised 3 ft (or 1 m) above the ground are both between 300 and 950 points. If the signal strength is too high with the receiver on the ground, lift the receiver until the signal is within an acceptable range. The second point should then be measured 3 ft (or 1 m) above that point. If the signal is too low, retract the tool to a shallower location for a stronger signal and try again.

3. Verify that roll and pitch values are displaying on the receiver and that the transmitter is sending a steady signal.
4. From the Main menu, select Calibration, then the 2-point calibration option.

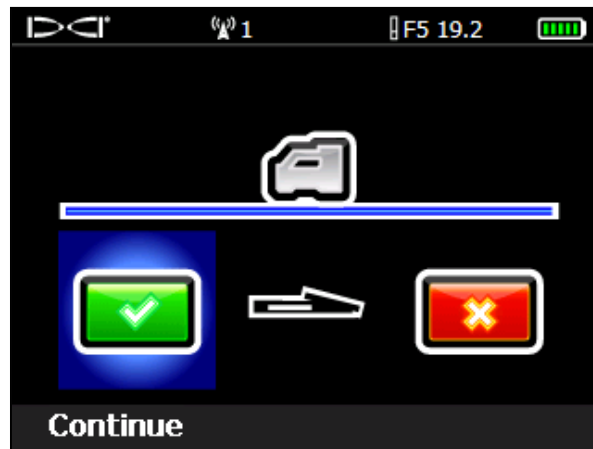

2-Point Calibration, Obtain 1st Point

5. Click the trigger to obtain the first calibration point. The calibration-in-progress screen displays. Do not move the receiver.
6. Once the first calibration point is obtained, the second calibration point screen appears.

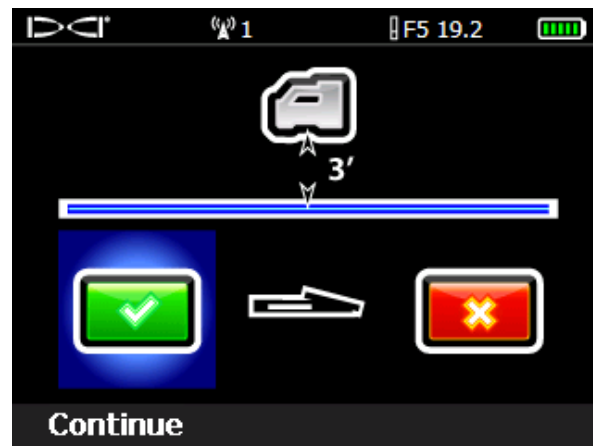

2-Point Calibration, Obtain 2nd Point

7. Lift the receiver 3 ft (or 1 m) directly up and click the trigger to initiate calibration of the second calibration point. The calibration-in-progress screen displays again. Do not move the receiver.

8. Once the second point is obtained, the receiver beeps four times and a checkmark displays on the screen, indicating a successful calibration. The screen will then return to the Locate Mode screen. If calibration fails, two long beeps will sound and a failure screen displays. Verify the setup and try again or call DCI Customer Service.



2-Point Calibration Failure Screen

After successfully completing the 2-point calibration procedure, verify the distance between the two calibration points by taking depth measurements at each point and then determining the difference between the two values. The difference should be 3 ft \pm 2 in. (or 1 m \pm 5 cm). Repeat these measurements several times as you continue drilling to verify that the depth remains valid as the pitch of the transmitter changes. This is called a two-point check.

If necessary, turn Height Above Ground (HAG) back on. See [Set Height-Above-Ground \(HAG\) Distance](#) on page 57 for more information.

View Calibration

Use View Calibration  to check the most recent calibrations for your transmitter(s). The data will include the model of transmitter, type of calibration (1-point or 2-point), signal strength, and a timestamp. Though this window lists all transmitters compatible with the F5 receiver, only transmitters calibrated to your receiver will display data in the Signal and Timestamp columns. Toggle down to view additional pages. Click the trigger to return to the Calibration menu.



Type	Cal. Type	Signal	Timestamp
F5 19.2	1Pt	570	2013-04-26
F5 12	1Pt	0	2013-04-26
F5 12 SH	1Pt	0	0000-00-00
F5 12 DH	1Pt	0	0000-00-00
F5 1.3 DL	1Pt	0	0000-00-00
F5 18.5	1Pt	0	0000-00-00
F5 8.4	1Pt	0	0000-00-00

Transmitter calibrations page 1/3

View Calibration Window

Set Roll Offset

Use Roll Offset to electronically compensate the 12 o'clock position of the transmitter to that of the drill head.

To set roll offset, at the receiver Main menu select Settings , then Roll Offset .

Enable Roll Offset

1. Select Set and enable roll offset from the Roll Offset menu.

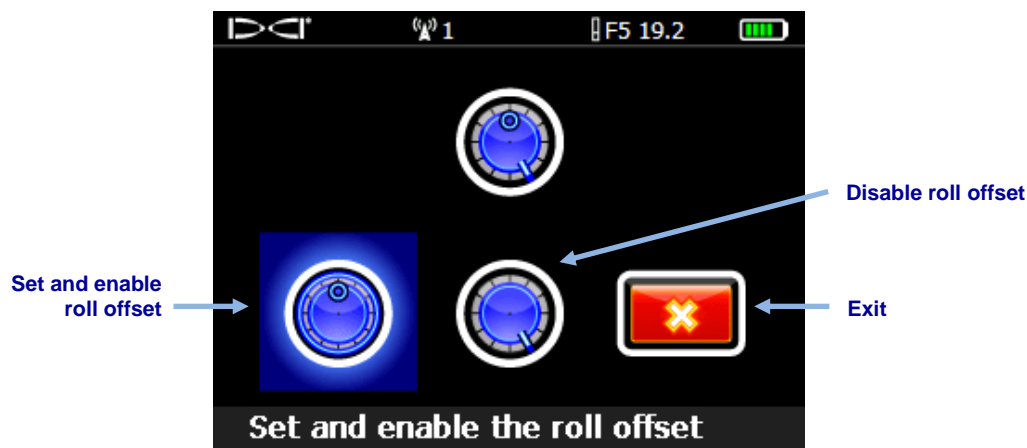

Roll Offset Menu

2. Ensure the drill head is at its 12 o'clock position and that the transmitter is on. Note the roll value showing on the screen.

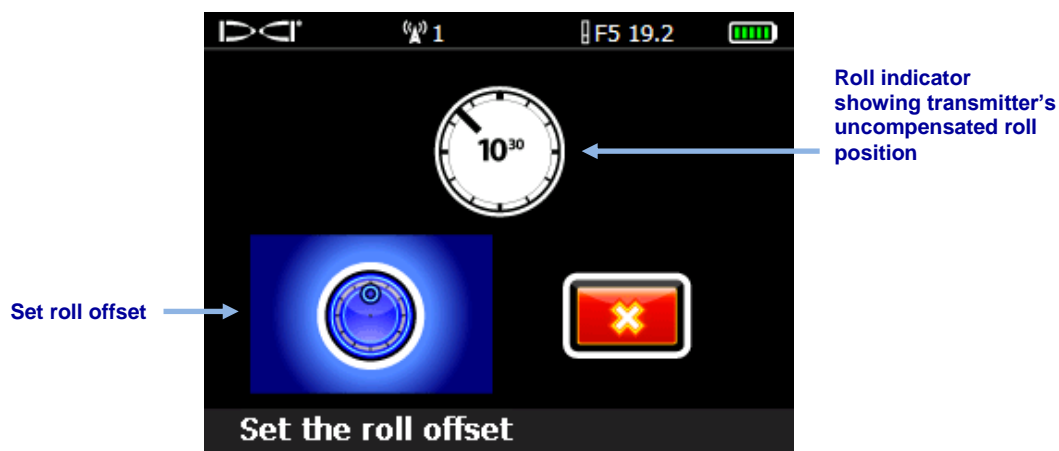

Set Roll Offset Menu

3. With the Set roll offset option highlighted as shown, click the trigger to set the roll offset. The receiver will beep four times as the screen returns to the Settings menu with roll offset enabled.

If the receiver does not detect a roll signal from the transmitter, the roll offset operation fails:



Roll Offset Failure Screen

Click the trigger to retry setting the roll offset or toggle right to select exit and return to the settings menu. If the roll offset failure screen appears, verify the setup and try again or contact DCI Customer Service.

Disable Roll Offset

To turn off the roll offset function, select the disable roll offset option from the roll offset menu. The receiver beeps four times as the screen returns to the Settings menu. The value that displays for roll on the Locate Mode screen will now be that of the transmitter, not necessarily the drill head.

Set Height-Above-Ground (HAG) Distance

Use height-above-ground (HAG)  to program a height measurement into the receiver so you don't have to set the receiver on the ground for a depth reading. Raising the receiver above the ground provides separation from underground interference, which can reduce the transmitter's range or cause variable readings.

To prevent incorrect readings, HAG must be manually enabled each time the F5 is turned on.

1. To determine your desired HAG distance, hold the receiver comfortably at your side and measure the distance from the bottom of the receiver to the ground. The available values range from 12–100 in. when English units are used, or 0.30–2.54 m when metric units are used.

- From the Main menu, select the HAG menu option. The HAG menu displays with the Enable HAG option highlighted for selection and the current or default (12 in. or 0.30 m) HAG setting shown in the description line at the bottom of the screen. If the HAG had previously been enabled, the disable option would show automatically highlighted for selection.

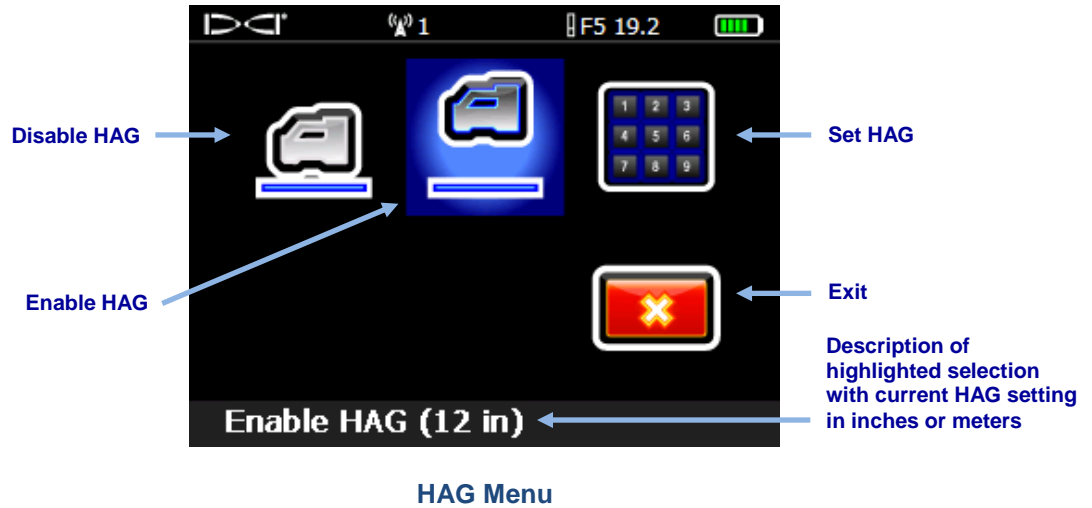

- To change the HAG value shown at the bottom of the screen, select Set HAG and enter a new value (for help with using the onscreen keypad, see [Using the Keypad](#) on page 22). After you press the execute button on that screen, the receiver beeps four times and returns to the Main menu. Select HAG again from the Main menu, then select Enable HAG to use your new HAG setting. Skip the following step.
- If the HAG value shown at the bottom of the screen is acceptable, select Enable HAG. The receiver beeps four times as it enables HAG and returns to the Main menu.

Depth readings (holding the trigger) must now be taken with the receiver held at this height.

As noted above, to prevent incorrect readings, HAG must be manually turned on each time the F5 is turned on.

Locating



Locating in a High-Interference Area with the F5 Receiver

Locating with the F5 system can become easy and intuitive. This section covers locating basics:

- front and rear locate points (FLP and RLP) and locate line (LL)
- geometry of FLP, RLP, and LL with respect to the transmitter
- the proper method for marking locate points
- tracking “on-the-fly” (while the tool is moving)
- off-track locating (when you cannot walk over the transmitter)

For a detailed explanation of how to track the transmitter when it is steep and deep, read the information provided in [Appendix B: Projected Depth Versus Actual Depth and the Fore/Aft Offset](#) on page 79.

Locating Basics

Locate Points (FLP & RLP) and Locate Line (LL)

The F5 receiver locates the transmitter by detecting three specific places in the transmitter's magnetic field: the front locate point (FLP) ahead of the transmitter, the rear locate point (RLP) behind the transmitter, and the locate line. The locate points are indistinguishable from one another by the receiver as they represent similar points in the transmitter's field in front of and behind the transmitter (see [Appendix B](#) on page 79 for more information about the transmitter's magnetic field).

The locate line (LL) extends 90° to the left and right of the transmitter (perpendicular) when the transmitter is at 0% pitch. It represents the location of the transmitter between the FLP and RLP. Think of the transmitter being the body of an airplane, and the locate line the wings.

The most accurate tracking requires the use of all three locations to determine the position, heading, and depth of the transmitter. Aligning the FLP and RLP reveals the heading and left/right position of the transmitter. The LL determines the central position and depth of the transmitter when the receiver is properly aligned between the FLP and RLP.

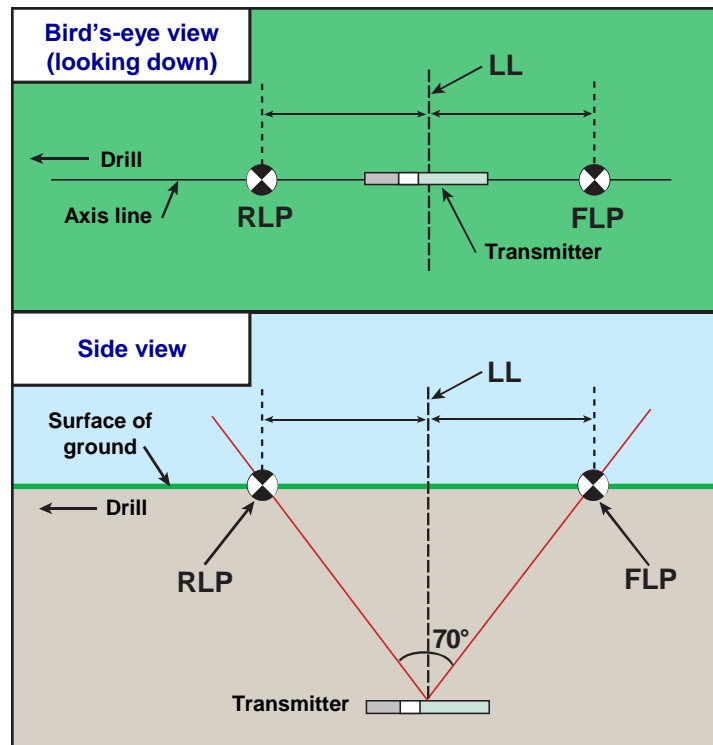

Geometry of FLP, RLP, and LL from Top (Bird's-Eye) and Side Views

Note how the RLP and FLP are equal distances from the LL when the transmitter is level.



Note If the transmitter pitch exceeds $\pm 30\%$ (or $\pm 17^\circ$) and/or the transmitter depth exceeds 15 ft (4.6 m), the position of the locate line will be somewhat ahead of or behind the transmitter's actual position. In these cases, the depth displayed on the receiver is referred to as the projected depth. [Appendix B](#) on page 79 provides more information regarding this situation.

Effects of Depth, Pitch, and Topography on Distance Between FLP and RLP

The deeper the transmitter is, the farther apart the FLP and RLP will be. The distance between the FLP and RLP with respect to the location of the LL is also a function of the transmitter pitch and the topography.

When the transmitter pitch is negative, the FLP will be farther from the LL than the RLP (see following figure). When the transmitter pitch is positive, the RLP will be further from the LL than the FLP. If the ground surface or topography slopes significantly, the locations of the FLP and RLP will also be affected with respect to the LL even if the transmitter itself is level.

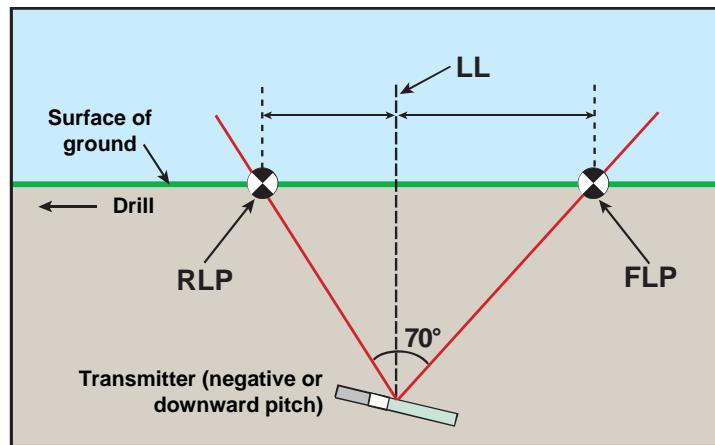

Effect of Pitch on Distance Between FLP, RLP, and LL

To calculate depth (for comparison to the receiver's depth reading) using the distance between the locate points and the pitch of the transmitter, see [Appendix C: Calculating Depth Based on Distance Between FLP and RLP](#) on page 84

Marking Locate Points

The locate points (FLP and RLP) and the locate line (LL) must be found and accurately marked during the locating procedure. To mark a locate point, stand with the receiver level at the locate point. Look down the vertical axis that runs through the center of the display to project a plumb line to the ground (see figure below). Mark where this plumb line hits the ground.

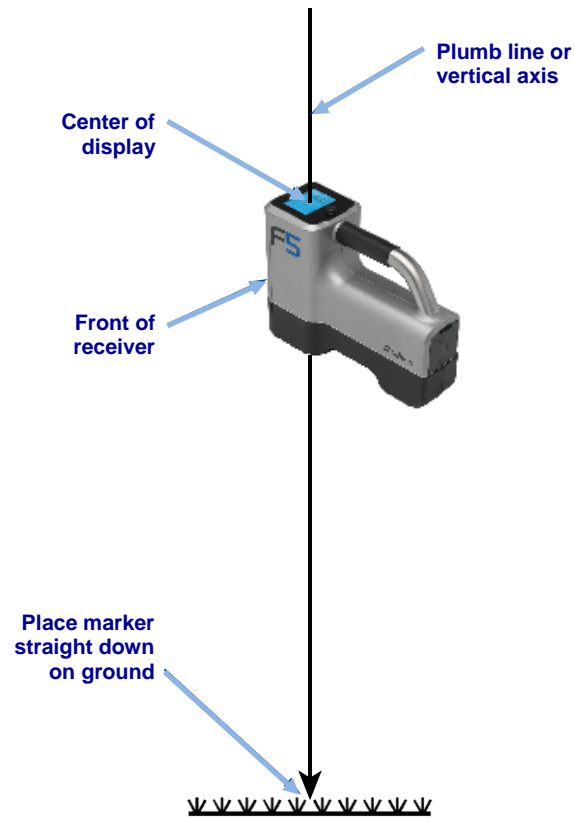

Plumb Line for Marking Locate Points

Standard Method for Locating the Transmitter

The F5 system can locate the transmitter *and* its heading while it moves, whether in front of the transmitter, behind it, or beside it. It can locate the transmitter facing toward or away from the drill rig.

The standard method described in this section guides the receiver to the transmitter while standing in front of it, facing the drill rig. This is the recommended method for locating. As you continue to drill or as the bore path curves, you may be facing the last marked locate point rather than the drill rig.

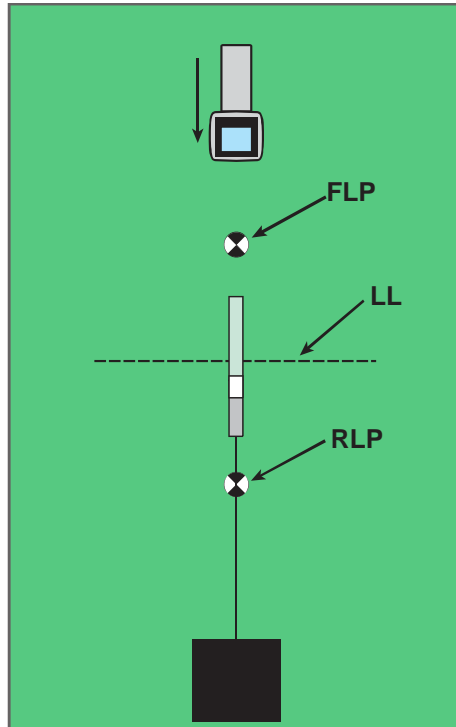

**Setup for
Standard Locating Method**

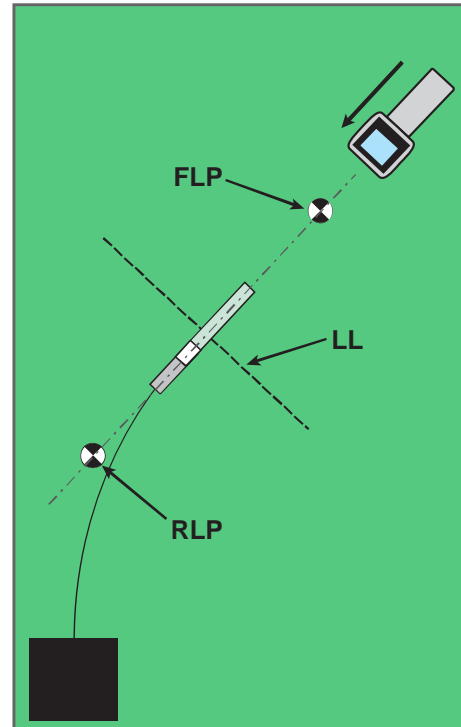

**Standard Locating Method
with a Curved Path**

Depth readings and data points for the drill DataLog function may be taken at the FLP or at the LL. Hold the trigger in to view the depth or predicted depth, to send the depth reading to the remote display, and to log data points for the drill DataLog function (see the [DigiTrak LWD DataLog System Operator's Manual](#) for complete instructions on logging data points).

Finding the Front Locate Point (FLP)

The locating procedure described here assumes you are facing the drill with the transmitter below ground and between you and the drill.

1. Start with the receiver on and in Locate mode.
2. Stand in front of the drill head at a distance of approximately one rod length.

- Observe the position of the locating target (⊗) relative to the receiver box on the display. The figures below show the FLP ahead of and to the left of the receiver; the FLP will be found farther in front of the drill head as the drill head gets deeper.

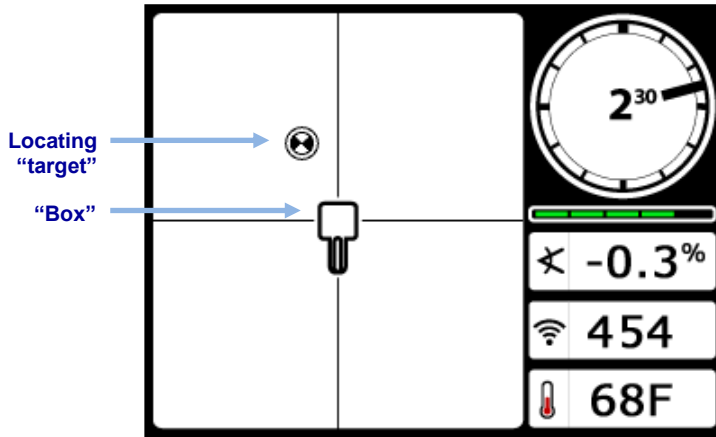

Receiver Locate Mode Screen

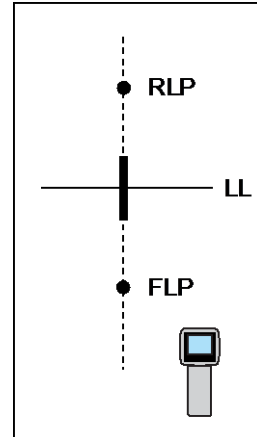

Actual Position of Receiver and Transmitter

- Move the receiver to guide the target into the box.
- When the target is centered in the box, hold the trigger in for one second so the receiver can "lock" on the reference signal. The "R" symbol will appear at the top of the depth screen. The locate line (LL) will not display later without this reference.

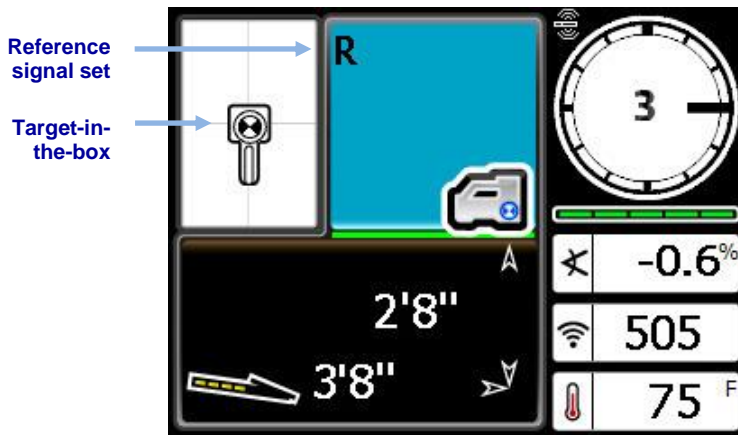

Receiver Depth Mode Screen (at FLP with HAG on)

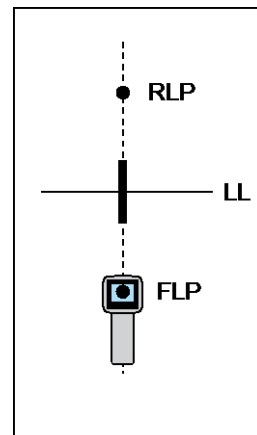

Actual Position of Receiver and Transmitter



Warning Do not hold the trigger in unless you are precisely at the FLP (target centered in box). If you are ahead of the FLP, you could set an incorrect reference that causes a ghost locate line. This typically happens when the head is shallower than 3 ft. (1 m). In this case, you must reference again at the FLP.

The depth value given at the FLP is the predicted depth, which is the depth the transmitter is calculated to be at when it reaches the location beneath the receiver. If the pitch or heading of the transmitter changes before it reaches the location under the receiver, the predicted depth reading will no longer be accurate.

To verify that the signal is balanced through the receiver's antenna, carefully rotate the receiver 360° about the center of the display while keeping the receiver level. The locating target should stay centered in the box. If it does not, do not continue to use the receiver and contact DCI Customer Service.

6. With the target centered in the box, mark the ground directly below the receiver's display screen as the FLP.

Finding the Locate Line

7. Continue to walk in the direction of the drill or the last known transmitter location. Keep the locating target on the vertical crosshair and observe that the signal strength is increasing.

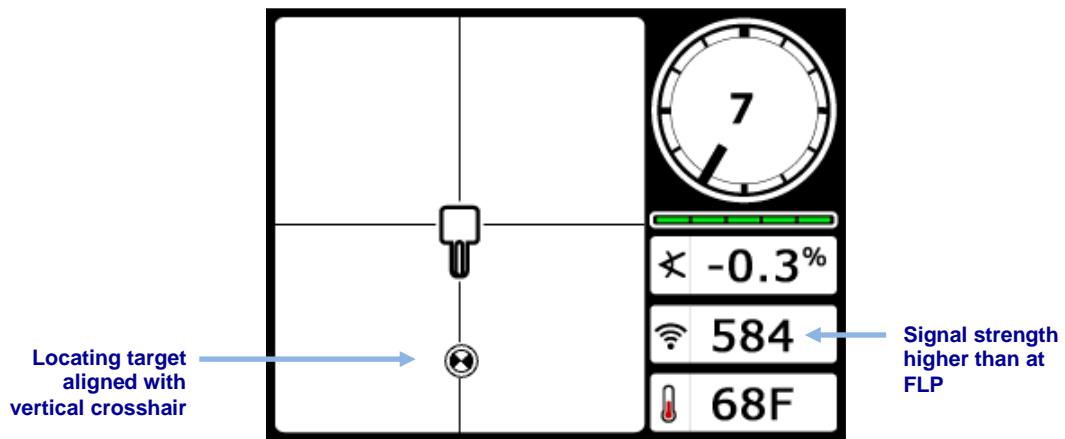

**Receiver Locate Mode Screen
(FLP Behind Receiver, Which Is Moving Toward LL)**

If the signal strength decreases, you may actually have just located the RLP. Position yourself further away from and facing the drill to locate the FLP.

8. When the locating target reaches the bottom of the screen, the locate line appears and the target turns solid black to indicate your focus should now be on the LL.

If the locate line does not appear and the ball flips to the top of the screen, move the receiver in a forward/backward direction over where the ball flips, then hold in the trigger to re-reference the receiver to the transmitter's signal and bring up the locate line.

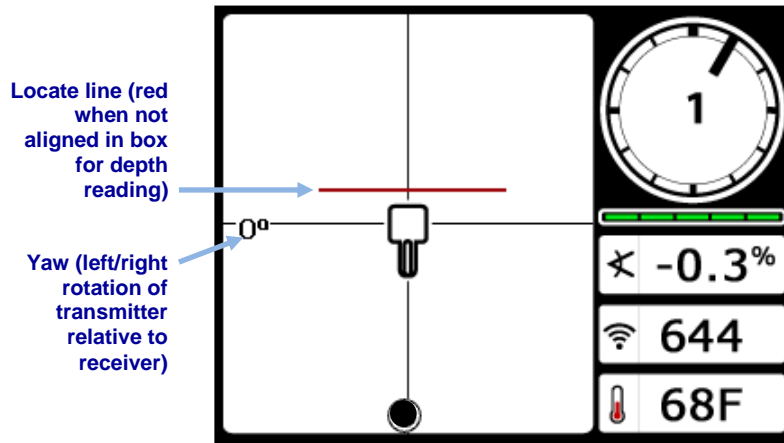

Receiver Locate Mode Screen (Approaching LL)

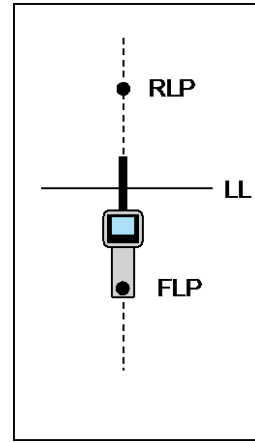

Actual Position of Receiver and Transmitter

Do not rely on the alignment of the ball with the vertical crosshair to identify the left/right position of the transmitter. Accurately locating the front and rear locate points is required to determine the transmitter's lateral position (heading) and take accurate depth readings.

- Position the receiver so the LL aligns with the horizontal crosshair.

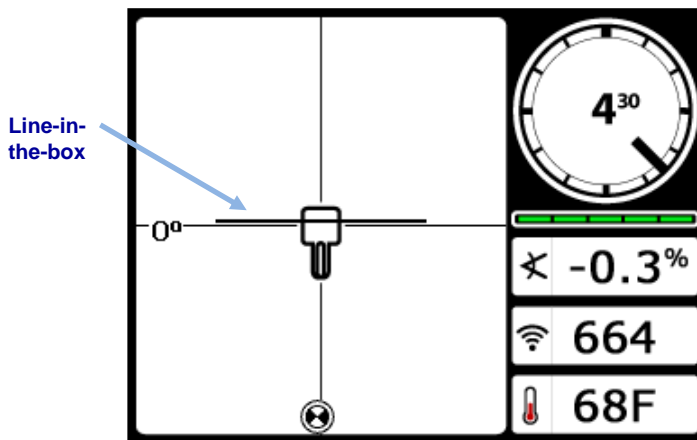

Receiver Locate Mode Screen (at the LL)

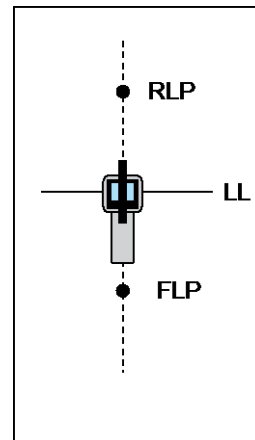

Actual Position of Receiver and Transmitter

- Mark the ground directly below the receiver's display screen as the LL. You could take a depth reading here by holding in the trigger, but to be certain you are directly above the transmitter and your depth reading is accurate, first find the RLP.

Finding the RLP to Confirm Transmitter Heading and Position

Finding the RLP will allow you to confirm the transmitter's heading and position. Like the FLP, the RLP is represented as a target () on the receiver display.

Continue locating as follows:

- From the LL, facing toward the drill or last transmitter location, walk forward while keeping the target aligned on the vertical crosshairs.

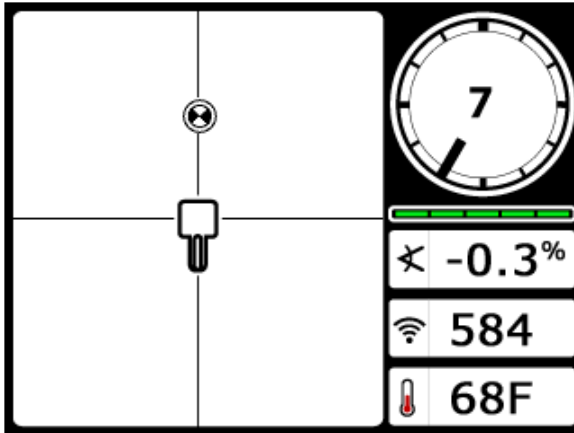

**Receiver Locate Mode Screen
(Approaching RLP from LL)**

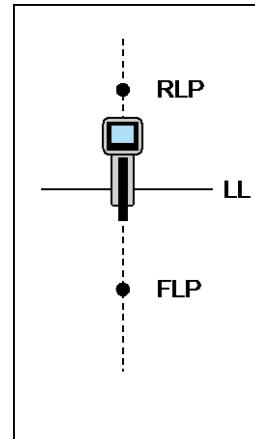

**Actual Position of Receiver
and Transmitter**

- Position the receiver so the locating target is centered in the box.

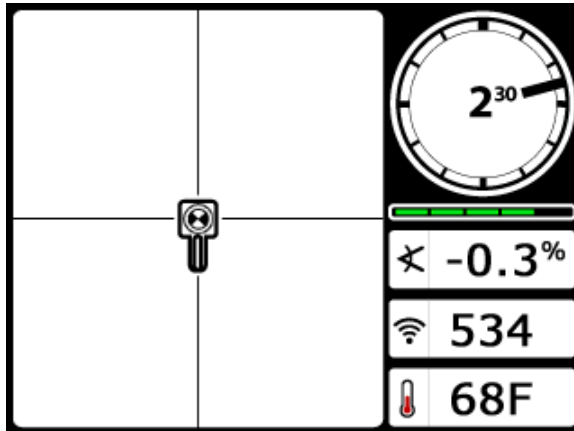

**Receiver Locate Mode Screen
(at RLP)**

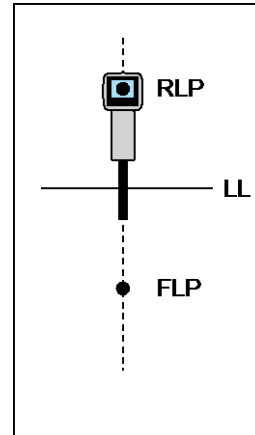

**Actual Position of Receiver
and Transmitter**

- Mark the ground directly below the receiver's display screen as the RLP.
- A line between the RLP and FLP represents the transmitter's heading. The transmitter is located beneath where this line and the LL cross.

- Position the receiver at the intersection of these lines with the LL passing through the center of the box on the display and hold the trigger to take a depth reading.

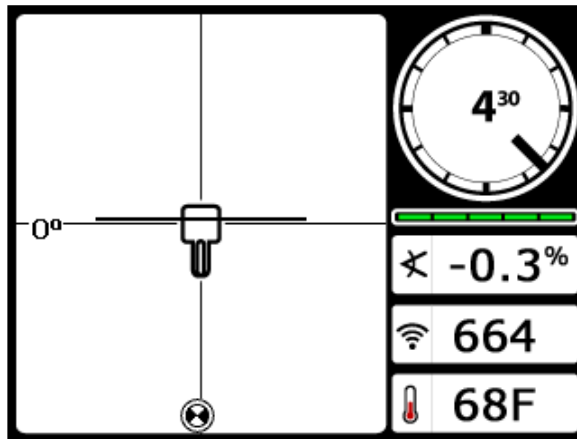

**Receiver Depth Mode Screen
(at LL)**

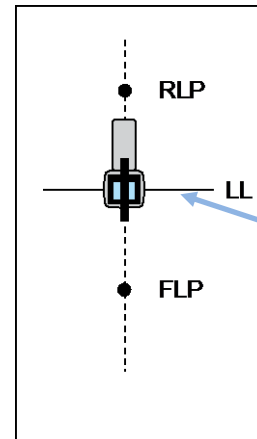

With LL aligned in box, receiver may face toward RLP or FLP during depth readings

Actual Position of Receiver and Transmitter

To verify the depth reading, disable the HAG, set the unit on the ground, and take another depth reading. This reading should be within 5% of the depth reading obtained with the HAG on and the receiver lifted.

See [Appendix B](#) on page 79 and [Appendix C](#) on page 84 for more information on depth.

Tracking "On-the-Fly"

If you are running at 0% (0°) pitch over level ground, the predicted depth will be the actual depth. In this case, all locating can be done at the FLP while the tool is moving.

Once the transmitter has been found and its heading is on line, position yourself the distance of one rod length in front of the FLP on the intended bore path with the receiver facing the drill and sitting level on the ground (see [Set Height-Above-Ground \(HAG\) Distance](#) on page 57 if you need to turn HAG off).

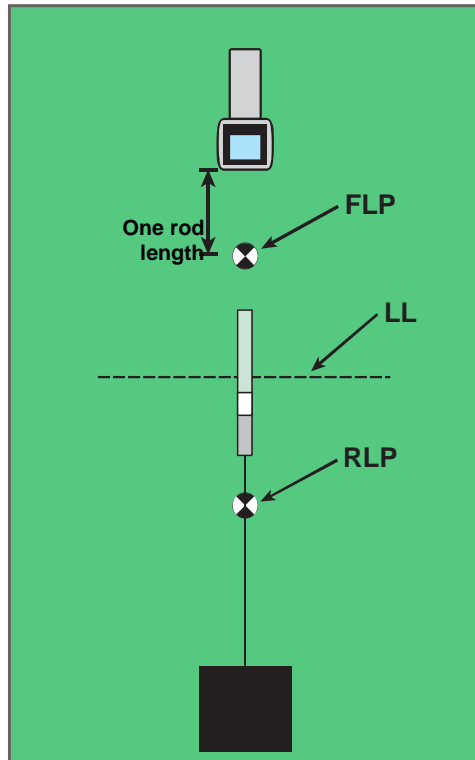

Tracking "On-the-Fly" with a Straight Path

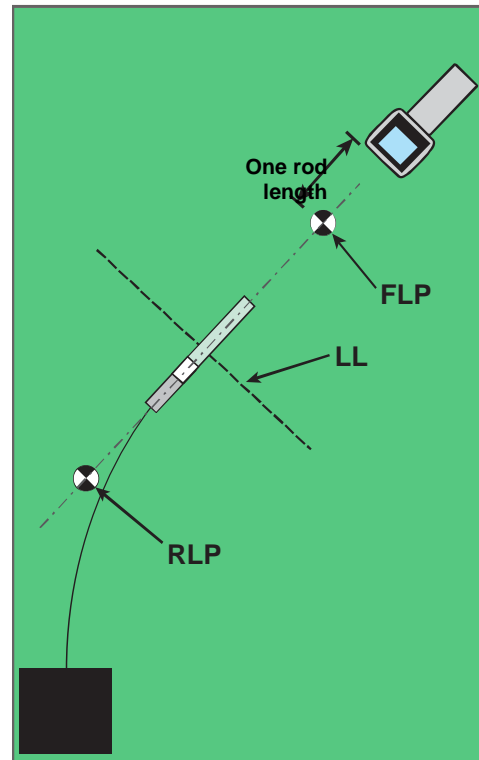

Tracking "On-the-Fly" with a Curved Path

Depth readings and data points for the drill DataLog function may be taken at the FLP or at the LL. Hold the trigger in to view the depth or predicted depth, to send the depth reading to the remote display, and to log data points. See the [DigiTrak LWD DataLog System Operator's Manual](#) for more information on logging data points.



Warning Do not hold the trigger in unless you are precisely at the FLP (target centered in box). If you are ahead of the FLP, you could set an incorrect reference that causes a ghost locate line. This typically happens when the head is shallower than 3 ft. (1 m). In this case, you must reference again at the FLP.

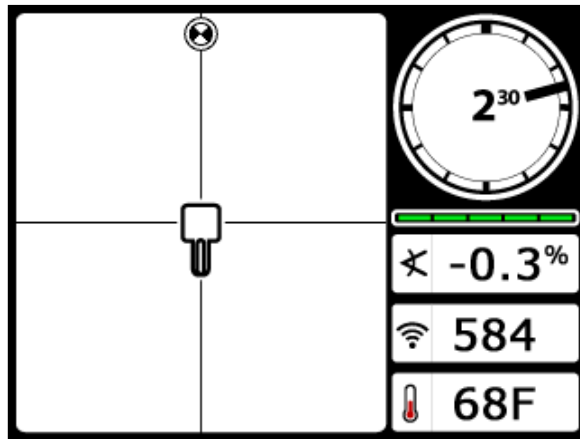

Receiver Screen Tracking "On-the-Fly"

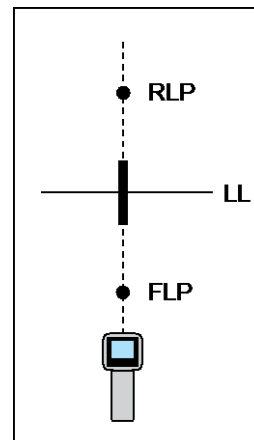

Actual Position of Receiver and Transmitter

As the drill head advances, the FLP should travel along the receiver's vertical crosshairs, indicating that the tool is still on line. Once the FLP is in the box, hold the trigger in and confirm that the predicted depth reading is as expected.

Off-Track Locating

Off-track locating is useful when it is not possible to walk above the transmitter due to a surface obstruction or interference. Using the locate line's perpendicular relationship to the transmitter, it is possible to track the transmitter's heading and also determine if it is maintaining its intended depth. The off-track locating method is only effective when the pitch of the transmitter is 0% (0°) and traveling under flat ground.

To explain how the off-track locating method works, we will use the example of an obstruction that is on the intended bore path, as shown in the figure below. The transmitter is about to go under the obstruction.

1. Stop drilling and find the locate line (LL) of the transmitter by putting the line in the box.
2. While holding the trigger in and keeping the receiver in the same orientation, step to the side until you reach a predetermined distance (P1). Move the receiver forward and backward until the ball jumps between the top and bottom of the screen, then mark this location.

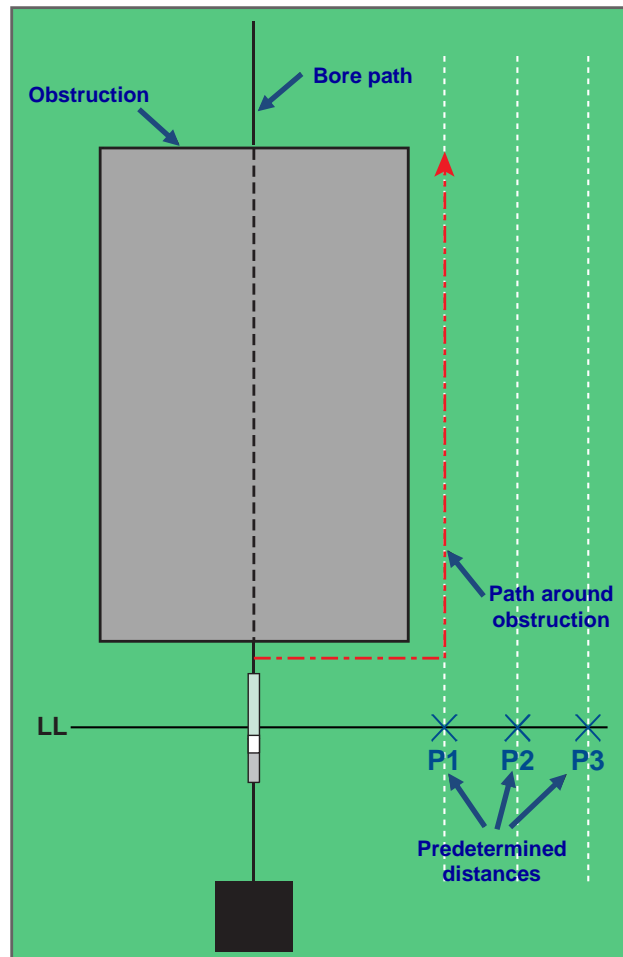

Preparing for Off-Track Locating

3. While still holding the trigger in and keeping the receiver in the same orientation, step to the side another predetermined distance (P2) farther away. Move the receiver forward and backward until the ball jumps between the top and bottom of the screen, then mark this location.
4. While still holding the trigger in and keeping the receiver in the same orientation, step to the side of the tool another predetermined distance (P3) farther away. Move the receiver forward and backward until the ball jumps between the top and bottom of the screen, then mark this location. Release the trigger.

5. Connect points P1, P2, and P3 with a line. This is the locate line. Because the LL runs perpendicular (at a 90° angle) to the transmitter when the transmitter is level, we can determine the heading of the tool. By comparing the signal strength at the predetermined distances of P1, P2, and P3, as the tool progresses, we can verify if the drill head is moving away from or maintaining the intended bore path. *It is important to track the pitch of the transmitter (see [Locate Mode Screen](#) on page 17) to verify that the tool is maintaining the desired depth.*
6. As drilling continues, steer the tool to maintain a constant signal strength at each of the points P1, P2, and P3. If the signal strength increases, the tool is moving away; if it decreases, the tool is moving toward the side position.

Differences in pitch will also affect the signal strength and LL position as the tool progresses.

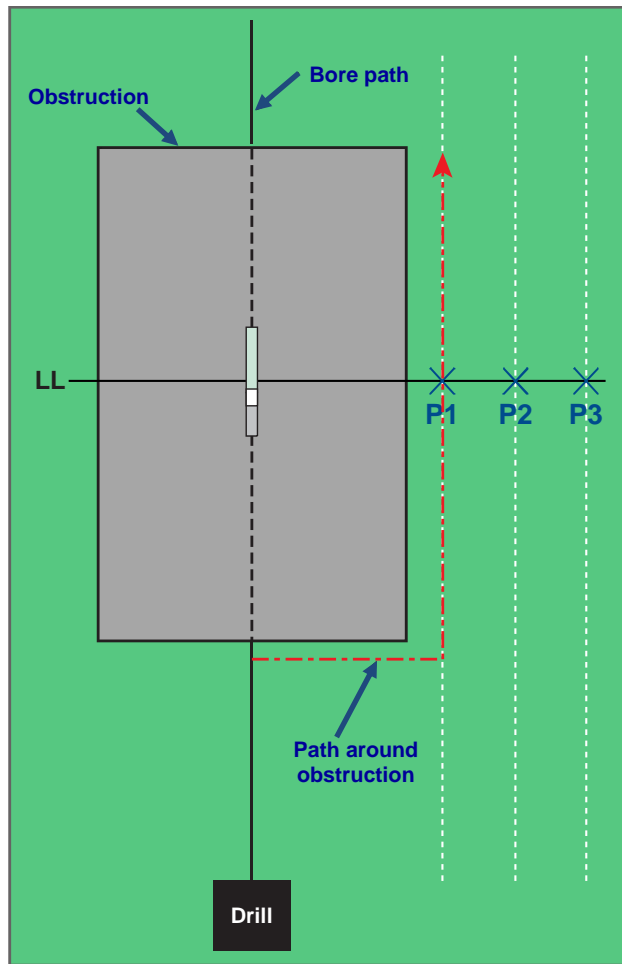

Off-Track Locating

Target Steering

The Target Steering feature on the remote display at the drill rig allows the drill head to be guided to a point directly below where the F5 receiver has been placed ahead of it.

Target Steering with the F5 system requires level topography for the most accurate results. It also assumes a conservative bend radius. Therefore, in situations with significant pitch changes, such as during the launch/exit ends, the up/down steering information on the remote display may not be accurate. In these situations, only the left/right steering information should be considered accurate.

Feasible Target Depth and Positioning the Receiver as a Target

The maximum distance the receiver can be placed ahead of the drill head for Target Steering is 35 ft (10.7 m). Beyond this distance, up/down steering information loses accuracy. Over the 35-ft (10.7-m) range, starting with the drill head approximately level, the following parameters apply:

- The maximum depth change is approximately 4 ft (1.2 m).
- The maximum pitch change is approximately 14%.

For the most conservative Target Steering operation, assume the ideal drill path is a circular arc with a radius that accommodates the bend radius of most drill strings and products being installed. As shown in the diagram below, the feasible steering area is limited to the shaded region bounded by the two circular arcs.

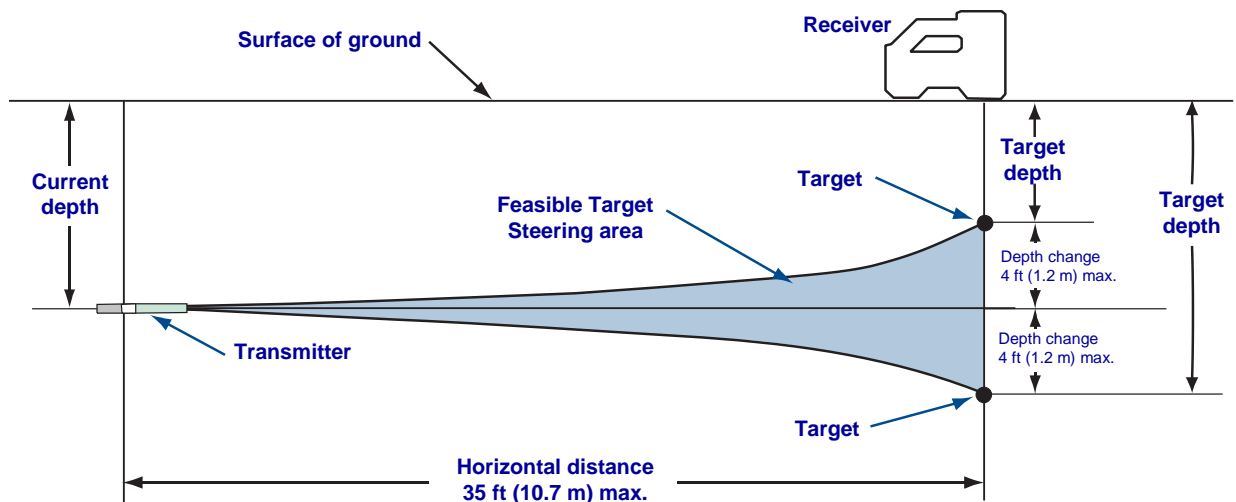

Diagram of Feasible Target Steering Area

Maximum depth change is approximately 4 ft (1.2 m) over horizontal distance of 35 ft (10.7 m).

The Target Steering procedure requires correct placement of the receiver at less than 35 ft (10.7 m) in front of the transmitter, on the bore path, with its back end (where the battery pack is inserted) facing the drill (or the last locate point, if drilling a curved path).

Setting the Receiver for Target Steering

The target depth is the depth at which you want the transmitter when it reaches the location under the receiver. To set the desired target depth on the F5, toggle up at the Locate Mode screen to open the Target Steering menu.

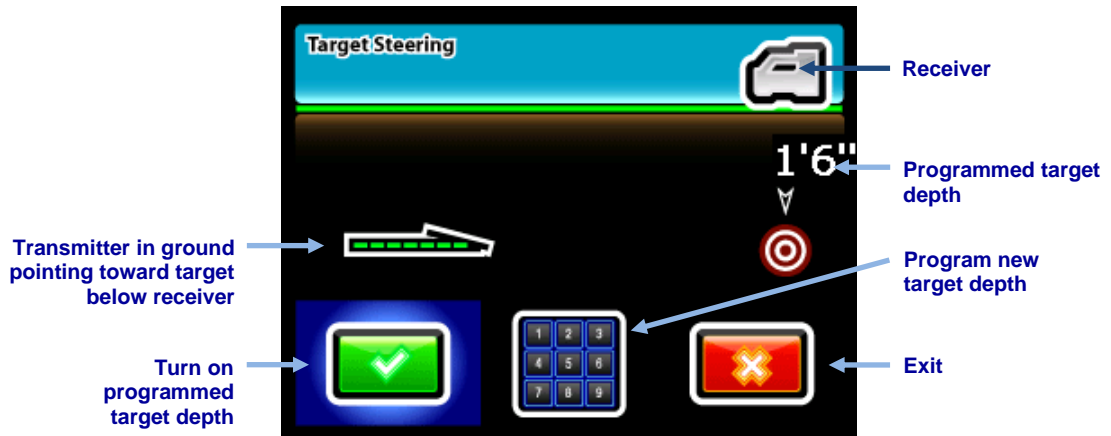

Target Steering Menu

The Target Steering menu displays either the last set target depth or the default value (1.5 ft., 18 in., or 0.46 m).

- To use the displayed value as the desired target depth, click the trigger.
- To enter a new target depth, select the keypad, enter the value in the appropriate units, and select the Return arrow (for help with using the onscreen keypad, see [Using the Keypad](#) on page 22).

The display returns to the Locate Mode screen with Target Steering activated, as shown in the following figure, and the remote receiver automatically changes to Target Steering locate mode.

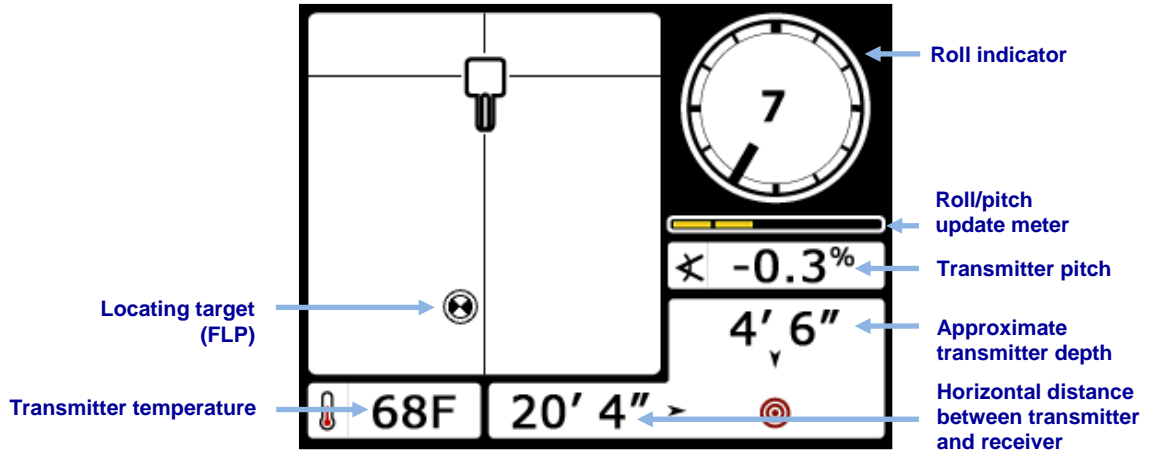

Target Steering Locate Mode Screen

The horizontal distance between transmitter and receiver is shown at the bottom. Use this number to help you position the receiver a maximum distance of 35 ft (10.7 m) ahead of the tool.

Pressure data for a fluid pressure sensing transmitter will display in a field between the transmitter pitch and approximate transmitter depth.

Steering to the Target

Once the target depth has been entered on the receiver and the receiver has been positioned ahead of the tool as the target, select Remote Mode from the remote display's (FSD) Main menu (see [Main Menu](#) on page 37) if the Target Steering screen is not yet displayed.

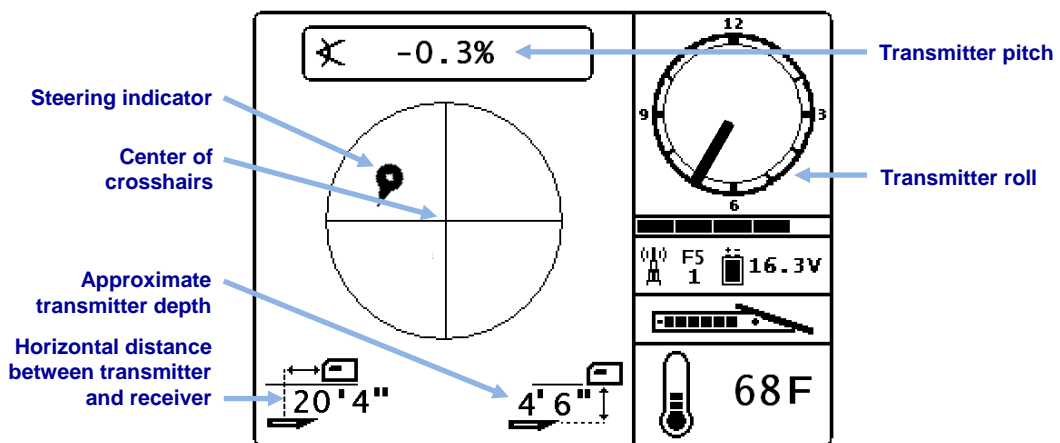

Target Steering on Remote Display

Imagine the crosshairs are pointing down the bore path, but instead of moving the crosshairs onto the target, you will steer the target onto the crosshairs. The pointed end of the steering indicator corresponds to the clock position of the head.

When the steering indicator is centered on the crosshairs, the drill head is correctly heading to the programmed target depth. The steering indicator in this case shows that the drill head is to the left and too high for the intended path. Rotating the drill head to the 4 o'clock position

will “point” the steering indicator toward the crosshairs and bring the drill head toward the target. The horizontal distance between transmitter (drill head) and receiver is indicated at the bottom left part of the display. The current approximate depth of the drill head is indicated at the bottom right.

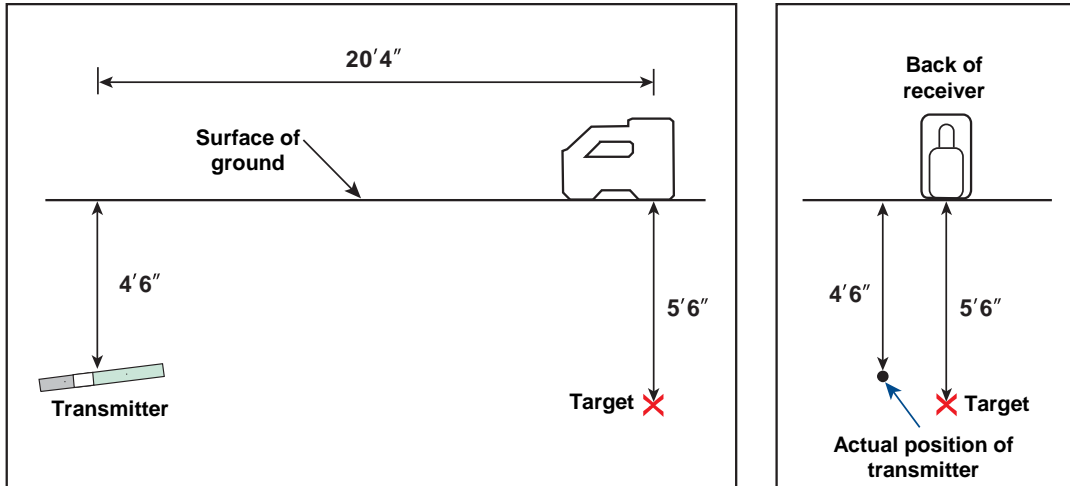

Side and End Views Showing Positions of Receiver, Transmitter, and Target

Target Steering in Interference Areas

In areas of passive and/or active interference, it may help to physically elevate the receiver above the ground. In the example below, the receiver is placed 3 ft (or 1 m) above the ground. To compensate, the target depth value is set to 8.5 ft. (2.6 m).

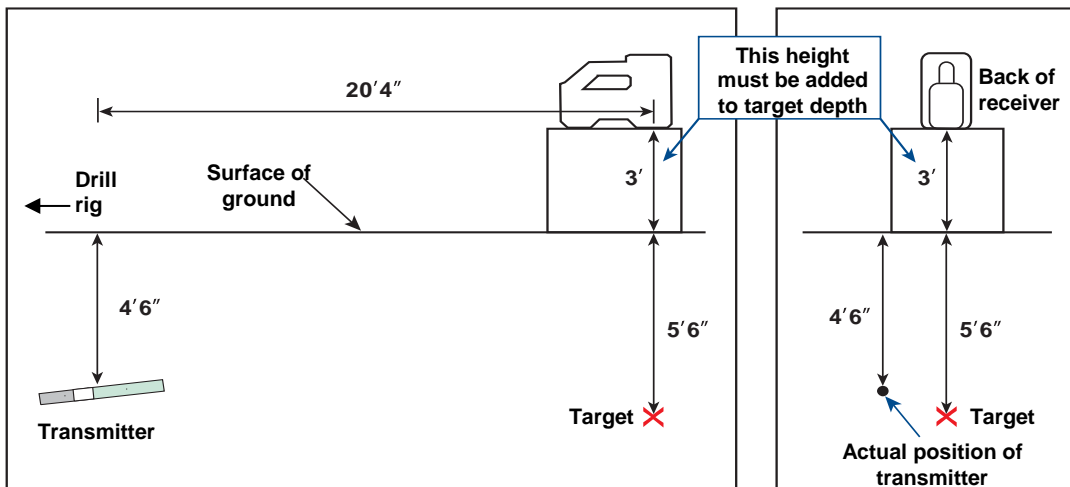

Side and Back End Views of Transmitter, Target, and Raised Receiver

Turn Off Target Steering

To turn off Target Steering, toggle down from the Target Steering screen to return to the standard Locate Mode screen. The F5 receiver will now no longer act as a steering target.

Appendix A: System Specifications and Maintenance Requirements

The power requirements, environmental requirements, and equipment maintenance requirements for the DigiTrak F5 Locating System are listed below.

Power Requirements

Device (Model Number)	Operational Voltage	Operational Current
DigiTrak F5 Receiver (F5R)	14.4 V ===	350 mA max
DigiTrak F Series Display (FSD)	10–28 V ===	3.2 W max
DigiTrak F Series Battery Charger (FBC)	Input 10–28 V === Output 19.2 V ===	5.0 A max 1.8 A max
DigiTrak F Series Lithium-Ion Battery Pack (FBP)	14.4 V ===	4.5 Ah, 65 Wh max
DigiTrak F Series Short-Range Transmitter (FS)	1.1–1.6 V ===	400 mA max
DigiTrak F Series Extended Long-Range Transmitters (FXL)	2–3.6 V ===	750 mA max
DigiTrak HDT and Fluid Pressure Transmitters (HDT, FPT)	1.7–7.2 V ===	650 mA max
DigiTrak DucTrak Transmitters (DDS 12, DDT 12)	2.4–3 V ===	130 mA max

Environmental Requirements

Device	Relative Humidity	Operating Temperature
DigiTrak F5 Receiver	<90%	-4 to 140° F (-20 to 60° C)
DigiTrak F Series Display	<90%	-4 to 140° F (-20 to 60° C)
DigiTrak FS Transmitter	<100%	-4 to 180° F (-20 to 82° C)
DigiTrak HDT and FXL Transmitters	<100%	-4 to 220° F (-20 to 104° C)
DigiTrak Fluid Pressure Transmitters	<100%	-4 to 220° F (-20 to 104° C)
DigiTrak DucTrak Transmitters	<100%	22 to 122° F (-5.6 to 50° C)
DigiTrak F Series Battery Charger	<99% for 32–50° F (0–10° C) <95% for 50–95° F (10–35° C)	32 to 95° F (0 to 35° C)
DigiTrak F Series Lithium-Ion Battery Pack	<99% for < 50° F (10° C) <95% for 50–95° F (10–35° C) <75% for 95–140° F (35–60° C)	-4 to 140° F (-20 to 60° C)

System working altitude: up to 6561 ft. (2000 m).

General Transmitter Care Instructions

Periodically clean the spring and threads inside the battery compartment as well as the spring and threads of the battery end cap to ensure a proper power connection with the batteries. Use an emery cloth or wire brush to remove any oxidation that has built up. Be careful not to damage the battery cap O-ring; remove it while cleaning if necessary. After cleaning, use a conductive lubricant on the battery cap threads to keep it from binding in the battery compartment.



Note All DCI battery-powered transmitters are shipped with a nickel-based anti-seize lubricant on the battery end cap, which aids in electrical grounding for better battery performance.

Before use, inspect the battery cap O-ring for damage that may allow water to enter the battery compartment. Replace the O-ring if the one installed becomes damaged.

Ensure the sensor ports in the fluid pressure transmitter remain open and free of debris. Clean with running water after every use. DO NOT use high-pressure fluid to clean the sensor ports.

Placing tape around the fiberglass tube of the transmitter, if space allows, will keep the fiberglass protected from most corrosive environmental wear.

HDT and FPT transmitters have a threaded hole (1/4"-20 thread) in the battery cap to allow the use of an insertion/extraction tool for installing and removing the transmitters in end-load housings. Ensure that this hole remains clear of debris.

Send in the Product Registration Card for the 90-day Limited Warranty.

Battery Pack Storage

If you plan to store the battery packs for any period of time, please follow these guidelines.

- Do not store the battery pack at temperatures greater than 113° F (45° C).
- Do not store the battery pack in a fully discharged state.
- Do not store the battery pack in the battery charger.
- If the battery pack will be stored for an extended period of time, pre-charge the battery to a charge level of 30% to 50% (two or three LEDs illuminated on the battery pack). Do not store the battery pack for more than one year unless it is periodically recharged to the 30% to 50% level.

Appendix B: Projected Depth Versus Actual Depth and the Fore/Aft Offset

What Happens When the Transmitter Is Steep and Deep

The signal field emitted by the transmitter, as shown in Figure B1, consists of a set of elliptical signals, or “flux lines”. The flux lines indicate the position of the transmitter. When the transmitter is level with respect to the ground, the locate line (LL) is directly over the transmitter, the depth displayed on the receiver is the actual depth, and the locate points (FLP and RLP) are at equal distances from the transmitter. The location of the LL is found at the intersection of the ground and the horizontal component of the flux field; the FLP and RLP are found where the vertical components of the flux field intersect with the ground. Some of the horizontal and vertical components are identified in Figure B1 by short yellow lines.

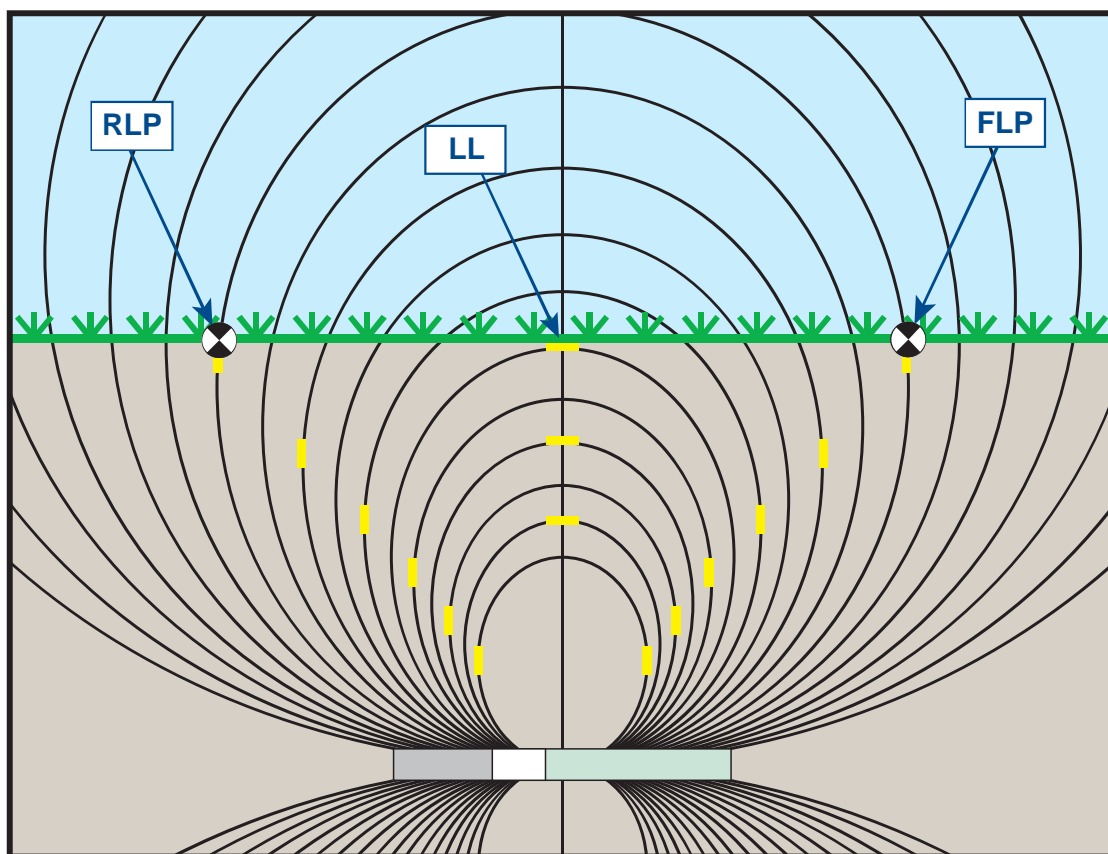

Figure B1. Flux Field and Geometry of FLP, RLP, and LL (Side View)

Due to the shape of the transmitter’s signal field, when it is at a pitch greater than $\pm 30\%$ ($\pm 17^\circ$) and/or a depth of 15 ft (4.6 m) or more, the position of the locate line will be some distance ahead of or behind the transmitter’s actual position. In this case, the depth displayed on the receiver becomes what is called the projected depth. The transmitter’s distance ahead of or behind the locate line is called the fore/aft offset.

The projected depth and fore/aft offset, shown in Figure B2, must be accounted for when the transmitter is steep and/or deep. See the tables provided later in this appendix ([Table B1](#) and [Table B2](#)) to determine the actual depth and fore/aft offset when you know the displayed (projected) depth and pitch of the transmitter.

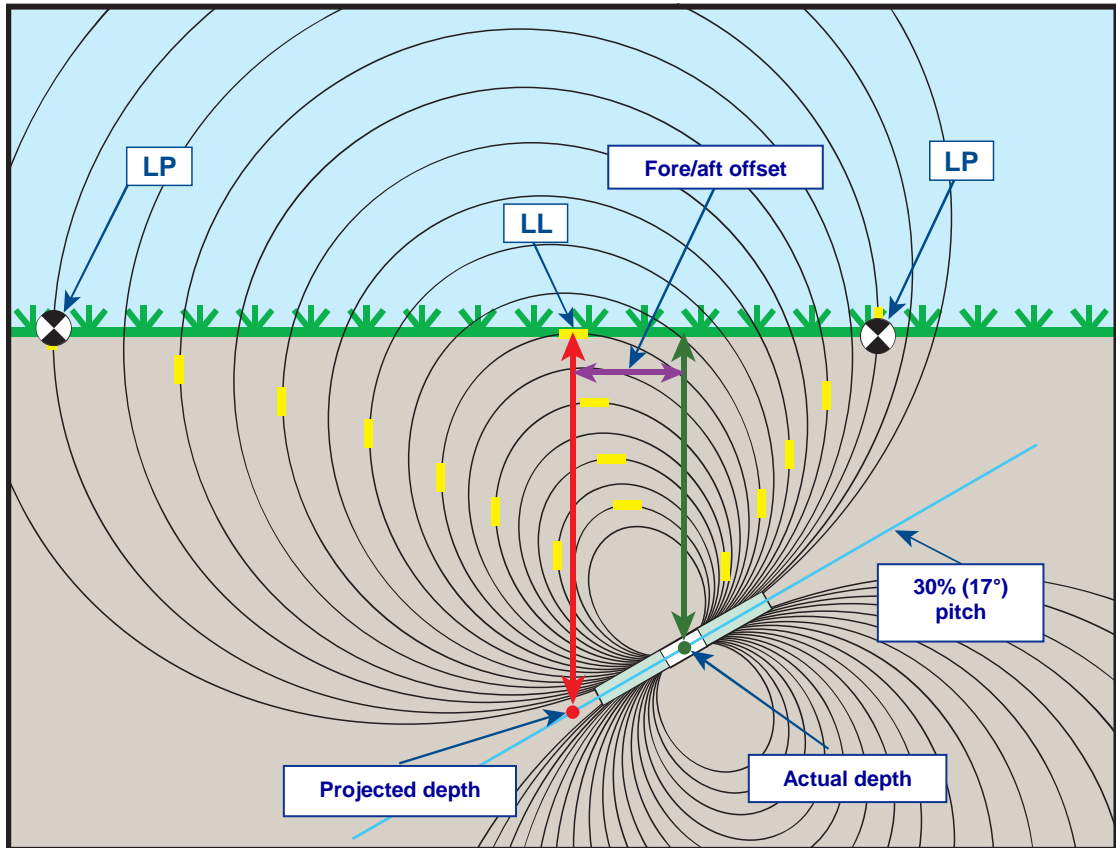

Figure B2. Projected Depth vs. Actual Depth and Fore/Aft Offset When Steep and Deep

Figure B2 shows a transmitter positioned in a drill string that is meant to illustrate drilling at either a positive or a negative pitch—the pitch is positive if you are drilling left to right, and it is negative if you are drilling right to left. The transmitter’s signal field is also pitched at the same angle as the transmitter. The locate line (LL), which is where the depth measurement is taken, is the horizontal component of the transmitter’s signal field flux lines. That is, the LL is found where the flux lines are horizontal, as illustrated with short horizontal yellow lines in the figure above.

The locate points (FLP and RLP) are also shown in Figure B2. These points are located at the vertical components of the signal field, as illustrated with short vertical yellow lines in the figure above. Note that the locate points are not the same distance from the LL when the transmitter is pitched. Again, this situation requires compensation for the projected depth and the fore/aft offset.

Using the tables provided below, you can look up the actual depth (Table B1) and the fore/aft offset (Table B2) based on the receiver’s depth reading (projected depth) and the transmitter pitch. You can also look up the projected depth (Table B3) if you know the required depth (actual depth) of your installation and you want to find the corresponding projected depth reading that you will see on the receiver during drilling. The final table (Table B4) provides conversion factors for determining the projected depth from the actual depth or the actual depth from the projected depth at various transmitter pitches.

Table B1 lists the projected or displayed depth values (shown in red) in 5 ft (1.52 m) increments in the first column and provides values for the actual depth (shown in green) at different transmitter pitches. For example, if you have a displayed depth of 25 ft (7.62 m) and your transmitter is at a 40% (22°) pitch, then you can see from Table B1 that the actual depth of the transmitter is 22 ft 8 in. (6.91 m).

Table B1. Determining Actual Depth from Displayed (Projected) Depth and Pitch

Pitch→ Displayed Depth ↓	±10% (5.7°)	±20% (11°)	±30% (17°)	±40% (22°)	±50% (27°)	±60% (31°)	±75% (37°)	±90% (42°)	±100% (45°)
5' (1.52 m)	5' (1.52 m)	4' 11" (1.50 m)	4' 9" (1.45 m)	4' 6" (1.37 m)	4' 4" (1.32 m)	4' 2" (1.27 m)	3' 10" (1.17 m)	3' 6" (1.07 m)	2' 6" (0.76 m)
10' (3.05 m)	9' 11" (3.02 m)	9' 9" (2.97 m)	9' 5" (2.87 m)	9' 1" (2.77 m)	8' 8" (2.64 m)	8' 3" (2.51 m)	7' 7" (2.31 m)	7' (2.13 m)	5' (1.52 m)
15' (4.57 m)	14' 11" (4.55 m)	14' 8" (4.47 m)	14' 2" (4.32 m)	13' 7" (4.14 m)	13' (3.96 m)	12' 5" (3.78 m)	11' 5" (3.48 m)	10' 6" (3.20 m)	7' 6" (2.29 m)
20' (6.10 m)	19' 11" (6.07 m)	19' 6" (5.94 m)	18' 10" (5.74 m)	18' 1" (5.51 m)	17' 4" (5.28 m)	16' 6" (5.03 m)	15' 3" (4.65 m)	14' (4.27 m)	10' (3.05 m)
25' (7.62 m)	24' 11" (7.59 m)	24' 5" (7.44 m)	23' 7" (7.19 m)	22' 8" (6.91 m)	21' 8" (6.60 m)	20' 8" (6.30 m)	19' (5.79 m)	17' 6" (5.33 m)	12' 6" (3.81 m)
30' (9.14 m)	29' 10" (9.09 m)	29' 3" (8.92 m)	28' 3" (8.61 m)	27' 2" (8.28 m)	26' (7.92 m)	24' 9" (7.54 m)	22' 10" (6.96 m)	21' (6.40 m)	15' (4.57 m)
35' (10.67 m)	34' 10" (10.62 m)	34' 2" (10.41 m)	33' 1" (10.08 m)	31' 8" (9.65 m)	30' 4" (9.25 m)	28' 11" (8.81 m)	26' 8" (8.13 m)	24' 6" (7.47 m)	17' 6" (5.33 m)
40' (12.19 m)	39' 10" (12.14 m)	39' (11.89 m)	37' 9" (11.51 m)	36' 2" (11.02 m)	34' 8" (10.57 m)	33' (10.06 m)	30' 5" (9.27 m)	28' (8.53 m)	20' (6.10 m)
45' (13.72 m)	44' 9" (13.64 m)	43' 11" (13.39 m)	42' 5" (12.93 m)	40' 9" (12.42 m)	39' (11.89 m)	37' 2" (11.33 m)	34' 3" (10.44 m)	31' 7" (9.63 m)	22' 6" (6.86 m)
50' (15.24 m)	49' 9" (15.16 m)	48' 9" (14.86 m)	47' 2" (14.38 m)	45' 3" (13.79 m)	43' 4" (13.21 m)	41' 3" (12.57 m)	38' 1" (11.61 m)	35' 1" (10.69 m)	25' (7.62 m)

Table B2 lists the projected or displayed depth values in 5 ft (1.52 m) increments in the first column and provides values for the fore/aft offset (shown in purple), rounded to the nearest inch (or cm) at different transmitter pitches.

Table B2. Determining Fore/Aft Offset from Displayed (Projected) Depth and Pitch

Pitch→ Displayed Depth ↓	±10% (5.7°)	±20% (11°)	±30% (17°)	±40% (22°)	±50% (27°)	±60% (31°)	±75% (37°)	±90% (42°)	±100% (45°)
5' (1.52 m)	4" (0.10 m)	8" (0.20 m)	11" (0.28 m)	1' 3" (0.38 m)	1' 7" (0.48 m)	1' 9" (0.53 m)	2' 1" (0.64 m)	2' 5" (0.74 m)	2' 6" (0.76 m)
10' (3.05 m)	8" (0.20 m)	1' 4" (0.41 m)	1' 11" (0.58 m)	2' 6" (0.76 m)	3' 1" (0.94 m)	3' 6" (1.07 m)	4' 2" (1.27 m)	4' 9" (1.45 m)	5' (1.52 m)
15' (4.57 m)	1' (0.30 m)	2' (0.61 m)	2' 11" (0.89 m)	3' 9" (1.14 m)	4' 7" (1.40 m)	5' 4" (1.63 m)	6' 3" (1.91 m)	7' 1" (2.16 m)	7' 6" (2.29 m)
20' (6.10 m)	1' 4" (0.41 m)	2' 7" (0.79 m)	3' 10" (1.17 m)	5' (1.52 m)	6' 1" (1.85 m)	7' 1" (2.16 m)	8' 4" (2.54 m)	9' 6" (2.90 m)	10' (3.05 m)
25' (7.62 m)	1' 8" (0.51 m)	3' 3" (0.99 m)	4' 10" (1.47 m)	6' 3" (1.91 m)	7' 7" (2.31 m)	8' 10" (2.69 m)	10' 5" (3.18 m)	11' 10" (3.61 m)	12' 6" (3.81 m)
30' (9.14 m)	2' (0.61 m)	3' 11" (1.19 m)	5' 10" (1.78 m)	7' 6" (2.29 m)	9' 2" (2.79 m)	10' 7" (3.23 m)	12' 6" (3.81 m)	14' 2" (4.32 m)	15' (4.57 m)
35' (10.67 m)	2' 4" (0.71 m)	4' 7" (1.40 m)	6' 9" (2.06 m)	8' 9" (2.67 m)	10' 8" (3.25 m)	12' 5" (3.78 m)	14' 8" (4.47 m)	16' 7" (5.05 m)	17' 6" (5.33 m)
40' (12.19 m)	2' 8" (0.81 m)	5' 3" (0.69 m)	7' 9" (2.36 m)	10' (3.05 m)	12' 2" (3.71 m)	14' 2" (4.32 m)	16' 9" (5.11 m)	18' 11" (5.77 m)	20' (6.10 m)
45' (13.72 m)	3' (0.91 m)	5' 11" (1.80 m)	8' 8" (2.64 m)	11' 4" (3.45 m)	13' 8" (4.17 m)	15' 11" (4.85 m)	18' 10" (5.74 m)	21' 3" (6.48 m)	22' 6" (6.86 m)
50' (15.24 m)	3' 4" (1.02 m)	6' 7" (2.01 m)	9' 4" (2.84 m)	12' 7" (3.84 m)	15' 3" (4.65 m)	17' 8" (5.38 m)	20' 11" (6.38 m)	23' 8" (7.21 m)	25' (7.62 m)

Table B3 on the following page lists the actual depths in 5 ft (1.52 m) increments in the first column and provides projected depth values at different transmitter pitches.

Table B3. Determining Projected Depth from Actual Depth and Pitch

Pitch → Actual Depth ↓	±10% (5.7°)	±20% (11°)	±30% (17°)	±40% (22°)	±50% (27°)	±60% (31°)	±75% (37°)	±90% (42°)	±100% (45°)
5' (1.52 m)	5' (1.52 m)	5' 2" (1.57 m)	5' 3" (1.60 m)	5' 6" (1.68 m)	5' 8" (1.73 m)	5' 11" (1.80 m)	6' 3" (1.91 m)	6' 6" (1.98 m)	7' 6" (2.29 m)
10' (3.05 m)	10' 1" (3.07 m)	10' 3" (3.12 m)	10' 7" (3.23 m)	10' 11" (3.33 m)	11' 4" (3.45 m)	11' 9" (3.58 m)	12' 5" (3.78 m)	13' (3.96 m)	15' (4.57 m)
15' (4.57 m)	15' 1" (4.60 m)	15' 5" (4.70 m)	15' 10" (4.83 m)	16' 5" (5.00 m)	17' (5.18 m)	17' 8" (5.38 m)	18' 7" (5.66 m)	19' 6" (5.94 m)	22' 6" (6.86 m)
20' (6.10 m)	20' 1" (6.12 m)	20' 6" (6.25 m)	21' 2" (6.45 m)	21' 11" (6.68 m)	22' 8" (6.91 m)	23' 6" (7.16 m)	24' 9" (7.54 m)	26' (7.92 m)	30' (9.14 m)
25' (7.62 m)	25' 2" (7.67 m)	25' 8" (7.82 m)	26' 5" (8.05 m)	27' 5" (8.36 m)	28' 4" (8.64 m)	29' 5" (8.97 m)	31' (9.45 m)	32' 6" (9.91 m)	37' 6" (11.43 m)
30' (9.14 m)	30' 2" (9.19 m)	30' 9" (9.37 m)	31' 9" (9.68 m)	32' 10" (10.01 m)	34' (10.36 m)	35' 3" (10.74 m)	37' 2" (11.33 m)	39' (11.89 m)	45' (13.72 m)
35' (10.67 m)	35' 2" (10.72 m)	35' 11" (10.95 m)	37' (11.28 m)	38' 4" (11.68 m)	36' 8" (11.18 m)	41' 2" (12.55 m)	43' 4" (13.21 m)	45' 6" (13.87 m)	52' 6" (16.00 m)
40' (12.19 m)	40' 2" (12.24 m)	41' (12.50 m)	42' 3" (12.88 m)	43' 10" (13.36 m)	45' 4" (13.82 m)	47' (14.33 m)	49' 7" (15.11 m)	52' (15.85 m)	60' (18.29 m)
45' (13.72 m)	45' 3" (13.79 m)	46' 2" (14.07 m)	47' 7" (14.50 m)	49' 3" (15.01 m)	51' (15.54 m)	52' 2" (15.90 m)	55' 9" (16.99 m)	58' 6" (17.83 m)	67' 6" (11.43 m)
50' (15.24 m)	50' 3" (15.32 m)	51' 3" (15.62 m)	52' 10" (16.10 m)	54' 9" (16.69 m)	56' 8" (17.27 m)	58' 9" (17.91 m)	61' 11" (18.87 m)	64' 11" (19.79 m)	75' (22.86 m)

Table B4 allows you to calculate the exact projected depth reading as well as the actual depth using a multiplier. Values for the multiplier, or conversion factor, are provided at different transmitter pitches.

Table B4. Conversion Factors for Calculating Exact Projected Depth or Actual Depth

Pitch →	±10% (5.7°)	±20% (11°)	±30% (17°)	±40% (22°)	±50% (27°)	±60% (31°)	±75% (37°)	±90% (42°)
From Actual to Projected Depth	1.005	1.025	1.06	1.105	1.155	1.212	1.314	1.426
From Projected to Actual Depth	0.995	0.975	0.943	0.905	0.866	0.825	0.761	0.701

For example, referring to Table B4, if you have a required (actual) depth of 24 ft (7.32 m), you can determine the receiver's projected depth reading at a 30% (17°) pitch. You will use the first row of conversion factors (From Actual to Projected Depth) to select the corresponding value for a pitch of 30%, which is 1.06. Multiply this value by the required depth, which is 24, and you will find that your receiver's projected depth reading at the locate line should display as 25 ft 5 in. (7.75 m).

Using the projected depth displayed on your receiver, you can calculate the actual depth of the transmitter using the second row of conversion factors. Select the corresponding conversion factor associated with your pitch value, then multiply that value by the projected depth. For example, if your pitch is 30% and your projected depth reading is 24 ft (7.32 m), then you would multiply 0.943 by 24 to determine that the actual depth of the transmitter is 22.63 ft or 22 ft 8 in. (6.90 m).

Appendix C: Calculating Depth Based on Distance Between FLP and RLP

It is possible to estimate the transmitter depth should the information displayed on the receiver become unreliable. This is only possible if you know the transmitter pitch and the positions of the front locate point (FLP) and the rear locate point (RLP) and if the ground surface is level.

To estimate the transmitter depth, first measure the distance between the FLP and the RLP. The pitch of the transmitter must also be reliably known. Using the Depth Estimation Table below, find the divider that most closely corresponds to the transmitter pitch. Then use the following formula to estimate the depth:

$$\text{Depth} = \frac{\text{Distance between FLP and RLP}}{\text{Divider}}$$

For example, if the transmitter pitch is 34% (or 18.8°) then the corresponding divider value (from the table) is 1.50. In this example, the distance between the FLP and the RLP is 11.5 ft (3.5 m). The depth would be:

$$\text{Depth} = \frac{11.5\text{ft}}{1.50} = 7.66\text{ft or approximately } 7.7 \text{ ft (2.35 m)}$$

Table C1. Depth Estimation Table

Pitch (% / °)	Divider	Pitch (% / °)	Divider	Pitch (% / °)	Divider
0 / 0.0	1.41	34 / 18.8	1.50	68 / 34.2	1.74
2 / 1.1	1.41	36 / 19.8	1.51	70 / 35.0	1.76
4 / 2.3	1.42	38 / 20.8	1.52	72 / 35.8	1.78
6 / 3.4	1.42	40 / 21.8	1.54	74 / 36.5	1.80
8 / 4.6	1.42	42 / 22.8	1.55	76 / 37.2	1.82
10 / 5.7	1.42	44 / 23.7	1.56	78 / 38.0	1.84
12 / 6.8	1.43	46 / 24.7	1.57	80 / 38.7	1.85
14 / 8.0	1.43	48 / 25.6	1.59	82 / 39.4	1.87
16 / 9.1	1.43	50 / 26.6	1.60	84 / 40.0	1.89
18 / 10.2	1.44	52 / 27.5	1.62	86 / 40.7	1.91
20 / 11.3	1.45	54 / 28.4	1.63	88 / 41.3	1.93
22 / 11.9	1.45	56 / 29.2	1.64	90 / 42.0	1.96
24 / 13.5	1.46	58 / 30.1	1.66	92 / 42.6	1.98
26 / 14.6	1.47	60 / 31.0	1.68	94 / 43.2	2.00
28 / 15.6	1.48	62 / 31.8	1.69	96 / 43.8	2.02
30 / 16.7	1.48	64 / 32.6	1.71	98 / 44.4	2.04
32 / 17.7	1.49	66 / 33.4	1.73	100 / 45.0	2.06

Appendix D: Reference Tables

Depth Increase in Inches (Centimeters) per 10-foot (3-meter) Rod

Percent	Depth Increase		Percent	Depth Increase
1	1 (2)		28	32 (81)
2	2 (5)		29	33 (84)
3	4 (10)		30	34 (86)
4	5 (13)		31	36 (91)
5	6 (15)		32	37 (94)
6	7 (18)		33	38 (97)
7	8 (20)		34	39 (99)
8	10 (25)		35	40 (102)
9	11 (28)		36	41 (104)
10	12 (30)		37	42 (107)
11	13 (33)		38	43 (109)
12	14 (36)		39	44 (112)
13	15 (38)		40	45 (114)
14	17 (43)		41	46 (117)
15	18 (46)		42	46 (117)
16	19 (48)		43	47 (119)
17	20 (51)		44	48 (122)
18	21 (53)		45	49 (124)
19	22 (56)		46	50 (127)
20	24 (61)		47	51 (130)
21	25 (64)		50	54 (137)
22	26 (66)		55	58 (147)
23	27 (69)		60	62 (157)
24	28 (71)		70	69 (175)
25	29 (74)		80	75 (191)
26	30 (76)		90	80 (203)
27	31 (79)		100	85 (216)

Depth Increase in Inches (Centimeters) per 15-foot (4.6-meter) Rod

Percent	Depth Increase		Percent	Depth Increase
1	2 (5)		28	49 (124)
2	4 (10)		29	50 (127)
3	5 (13)		30	52 (132)
4	7 (18)		31	53 (135)
5	9 (23)		32	55 (140)
6	11 (28)		33	56 (142)
7	13 (33)		34	58 (147)
8	14 (36)		35	59 (150)
9	16 (41)		36	61 (155)
10	18 (46)		37	62 (157)
11	20 (51)		38	64 (163)
12	21 (53)		39	65 (165)
13	23 (58)		40	67 (170)
14	25 (64)		41	68 (173)
15	27 (69)		42	70 (178)
16	28 (71)		43	71 (180)
17	30 (76)		44	72 (183)
18	32 (81)		45	74 (188)
19	34 (86)		46	75 (191)
20	35 (89)		47	77 (196)
21	37 (94)		50	80 (203)
22	39 (99)		55	87 (221)
23	40 (102)		60	93 (236)
24	42 (107)		70	103 (262)
25	44 (112)		80	112 (284)
26	45 (114)		90	120 (305)
27	47 (119)		100	127 (323)

LIMITED WARRANTY

Digital Control Incorporated ("DCI") warrants that when shipped from DCI each DCI Product will conform to DCI's current published specifications in existence at the time of shipment and will be free, for the warranty period ("Warranty Period") described below, from defects in materials and workmanship. The limited warranty described herein ("Limited Warranty") is not transferable, shall extend only to the first end-user ("User") purchasing the DCI Product from either DCI or a dealer expressly authorized by DCI to sell DCI Products ("Authorized DCI Dealer"), and is subject to the following terms, conditions and limitations:

1. A Warranty Period of twelve (12) months shall apply to the following new DCI Products: receivers/locators, remote displays, battery chargers and rechargeable batteries, and DataLog[®] modules and interfaces. A Warranty Period of ninety (90) days shall apply to all other new DCI Products, including transmitters, accessories, and software programs and modules. Unless otherwise stated by DCI, a Warranty Period of ninety (90) days shall apply to: (a) a used DCI Product sold either by DCI or by an Authorized DCI Dealer who has been expressly authorized by DCI to sell such used DCI Product; and (b) services provided by DCI, including testing, servicing, and repairing an out-of-warranty DCI Product. The Warranty Period shall begin from the later of: (i) the date of shipment of the DCI Product from DCI, or (ii) the date of shipment (or other delivery) of the DCI Product from an Authorized DCI Dealer to User.
2. DCI's sole obligation under this Limited Warranty shall be limited to either repairing, replacing, or adjusting, at DCI's option, a covered DCI Product that has been determined by DCI, after reasonable inspection, to be defective during the foregoing Warranty Period. All warranty inspections, repairs and adjustments must be performed either by DCI or by a warranty claim service authorized in writing by DCI. All warranty claims must include proof of purchase, including proof of purchase date, identifying the DCI Product by serial number.
3. The Limited Warranty shall only be effective if: (i) within fourteen (14) days of receipt of the DCI Product, User mails a fully completed Product Registration Card to DCI; (ii) User makes a reasonable inspection upon first receipt of the DCI Product and immediately notifies DCI of any apparent defect; and (iii) User complies with all of the Warranty Claim Procedures described below.

WHAT IS NOT COVERED

This Limited Warranty excludes all damage, including damage to any DCI Product, due to: failure to follow DCI's operator's manual and other DCI instructions; abuse; misuse; neglect; accident; fire; flood; Acts of God; improper applications; connection to incorrect line voltages and improper power sources; use of incorrect fuses; overheating; contact with high voltages or injurious substances; use of batteries or other products or components not manufactured or supplied by DCI; or other events beyond the control of DCI. This Limited Warranty does not apply to any equipment not manufactured or supplied by DCI nor, if applicable, to any damage or loss resulting from use of any DCI Product outside the designated country of use. By accepting a DCI Product and not returning it for a refund within thirty (30) days of purchase, User agrees to the terms of this Limited Warranty, including without limitation the Limitation of Remedies and Liability described below, and agrees to carefully evaluate the suitability of the DCI Product for User's intended use and to thoroughly read and strictly follow all instructions supplied by DCI (including any updated DCI Product information which may be obtained at the above DCI website). In no event shall this Limited Warranty cover any damage arising during shipment of the DCI Product to or from DCI.

User agrees that the following will render the above Limited Warranty void: (i) alteration, removal or tampering with any serial number, identification, instructional, or sealing labels on the DCI Product, or (ii) any unauthorized disassembly, repair or modification of the DCI Product. In no event shall DCI be responsible for the cost of or any damage resulting from any changes, modifications, or repairs to the DCI Product not expressly authorized in writing by DCI, and DCI shall not be responsible for the loss of or damage to the DCI Product or any other equipment while in the possession of any service agency not authorized by DCI.

DCI reserves the right to make changes in design and improvements upon DCI Products from time to time, and User understands that DCI shall have no obligation to upgrade any previously manufactured DCI Product to include any such changes.

THE FOREGOING LIMITED WARRANTY IS DCI'S SOLE WARRANTY AND IS MADE IN PLACE OF ALL OTHER WARRANTIES, EXPRESS OR IMPLIED, INCLUDING BUT NOT LIMITED TO THE IMPLIED WARRANTIES OF MERCHANTABILITY AND FITNESS FOR A PARTICULAR PURPOSE, IMPLIED WARRANTY OF NON-INFRINGEMENT, AND ANY IMPLIED WARRANTY ARISING FROM COURSE OF PERFORMANCE, COURSE OF DEALING, OR USAGE OF TRADE, ALL OF WHICH ARE HEREBY DISCLAIMED AND EXCLUDED. If DCI has substantially complied with the warranty claim procedures described below, such procedures shall constitute User's sole and exclusive remedy for breach of the Limited Warranty.

LIMITATION OF REMEDIES AND LIABILITY

In no event shall DCI or anyone else involved in the creation, production, or delivery of the DCI Product be liable for any damages arising out of the use or inability to use the DCI Product, including but not limited to indirect, special, incidental, or consequential damages, or for any cover, loss of information, profit, revenue or use, based upon any claim by User for breach of warranty, breach of contract, negligence, strict liability, or any other legal theory, even if DCI has been advised of the possibility of such damages. In no event shall DCI's liability exceed the amount User has paid for the DCI Product. To the extent that any applicable law does not allow the exclusion or limitation of incidental, consequential or similar damages, the foregoing limitations regarding such damages shall not apply.

This Limited Warranty gives you specific legal rights, and you may also have other rights which vary from state to state. This Limited Warranty shall be governed by the laws of the State of Washington.

WARRANTY CLAIM PROCEDURES

1. If you are having problems with your DCI Product, you must first contact the Authorized DCI Dealer where it was purchased. If you are unable to resolve the problem through your Authorized DCI Dealer, contact DCI's Customer Service Department in Kent, Washington, USA at the above telephone number between 6:00 a.m. and 6:00 p.m. Pacific Time and ask to speak with a customer service representative. (The above "800" number is available for use only in the USA and Canada.) Prior to returning any DCI Product to DCI for service, you must obtain a Return Merchandise Authorization (RMA) number. Failure to obtain an RMA may result in delays or return to you of the DCI Product without repair.
2. After contacting a DCI customer service representative by telephone, the representative will attempt to assist you in troubleshooting while you are using the DCI Product during actual field operations. Please have all related equipment available together with a list of all DCI Product serial numbers. It is important that field troubleshooting be conducted because many problems do not result from a defective DCI Product, but instead are due to either operational errors or adverse conditions occurring in the User's drilling environment.
3. If a DCI Product problem is confirmed as a result of field troubleshooting discussions with a DCI customer service representative, the representative will issue an RMA number authorizing the return of the DCI Product and will provide shipping directions. You will be responsible for all shipping costs, including any insurance. If, after receiving the DCI Product and performing diagnostic testing, DCI determines the problem is covered by the Limited Warranty, required repairs and/or adjustments will be made, and a properly functioning DCI Product will be promptly shipped to you. If the problem is not covered by the Limited Warranty, you will be informed of the reason and be provided an estimate of repair costs. If you authorize DCI to service or repair the DCI Product, the work will be promptly performed and the DCI Product will be shipped to you. You will be billed for any costs for testing, repairs and adjustments not covered by the Limited Warranty and for shipping costs. In most cases, repairs are accomplished within 1 to 2 weeks.
4. DCI has a limited supply of loaner equipment available. If loaner equipment is required by you and is available, DCI will attempt to ship loaner equipment to you by overnight delivery for your use while your equipment is being serviced by DCI. DCI will make reasonable efforts to minimize your downtime on warranty claims, limited by circumstances not within DCI's control. If DCI provides you loaner equipment, your equipment must be received by DCI no later than the second business day after your receipt of loaner equipment. You must return the loaner equipment by overnight delivery for receipt by DCI no later than the second business day after your receipt of the repaired DCI Product. Any failure to meet these deadlines will result in a rental charge for use of the loaner equipment for each extra day the return of the loaner equipment to DCI is delayed.